

**Office** 7F, 20, Pangyoyeok-ro 241beon-gil, Bundang-gu, Seongnam-si, Gyeonggi-do, Republic of Korea  
Tel. +82-70-7147-5071 Email. mtinfo@hanwha.com

**Factory** 9, Seongsanpaechong-ro, Seongsan-gu, Changwon-si, Gyeongsangnam-do, Republic of Korea



## Hanwha Europe GmbH Technical Center

Hessenring 15B, 64546 Mörfelden-Walldorf, Germany

· Tel. +49-(0)-6105-7035-911

· E mail. wsjung@hanwha.de

## Hanwha Europe Istanbul Branch

İstasyon Mah. Yarış Çıkmazı Sk. No:1 Dükkan No: B/ 24

Tuzla/ İstanbul

· Tel. +90-531-435-1744

· E mail. djkoo@hanwha.de

### EUROPE

Belgium · Bulgaria · Croatia · Czech Republic  
Finland · France · Germany · Hungary · Italy  
Netherland · Poland · Portugal · Romania  
Russia · Spain · Sweden · Switzerland · Turkey  
U.K. · Ukraine

### ASIA

China · Hong Kong · India · Indonesia  
Israel · Malaysia · Philippines · Thailand  
Vietnam

### AMERICA

USA · Argentina · Brazil · Canada  
Costa Rica · Mexico

## Hanwha Machinery America Inc.

9750 South Oakwood Park Drive, Franklin, WI 53132, USA

· Tel. +1-414-421-2300

· E mail. jeff@hanwhamachinery.com

## Hanwha Machinery America Chicago Office

1455 Payne Road, Schaumburg, IL, 60173

· Mobile. +1-224-833-1860

· E mail. tommy@hanwhamachinery.com

# Hanwha Machine Tools

## CNC Swiss Turning Lathe

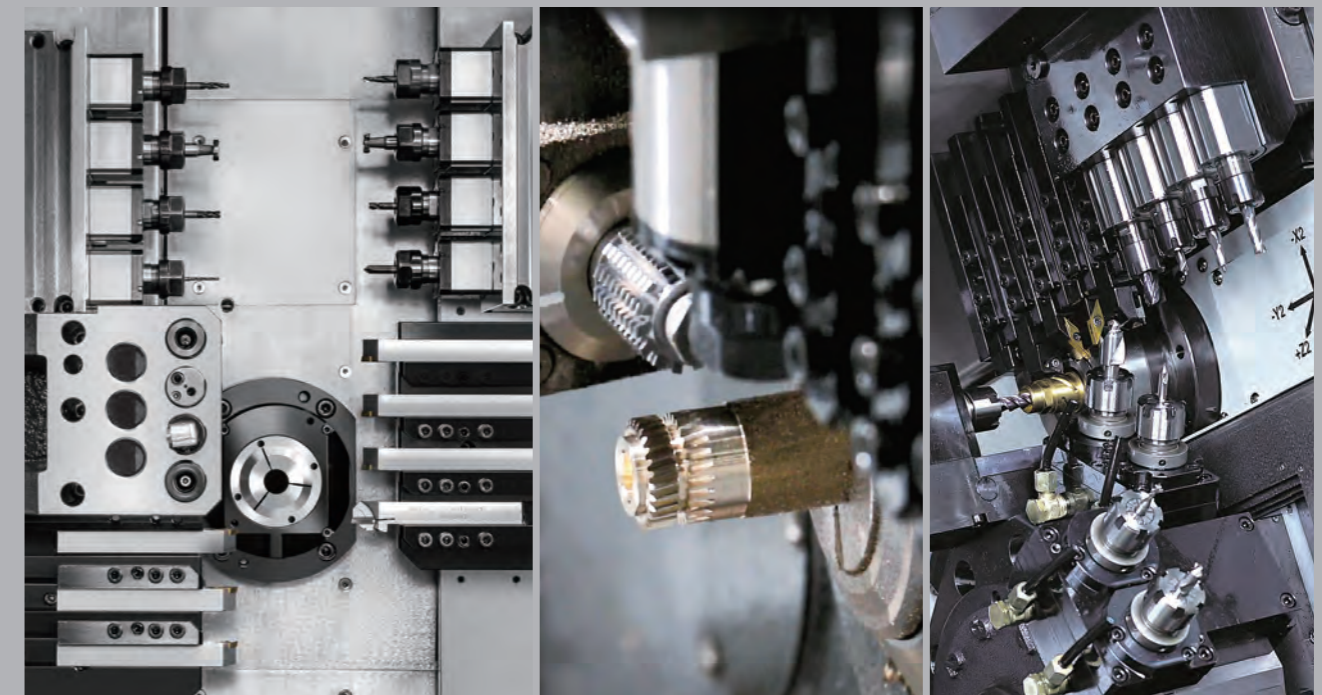

2024. AUGUST © 2024 Hanwha Precision Machinery Co., Ltd. All rights reserved.

※ Please note specifications are based on an optimized condition, and a subject to change without prior notification.

# Advanced Manufacturing Solution Creator

Hanwha Precision Machinery is a leading global equipment manufacturer with business in Machine Tools, SMT, Semiconductor and manufacturing software solutions for automation. Machine Tools started back in 1977 and has been growing in both business and technology. In 2024, using 47 years of expertise and experience in machine tools, Hanwha is launching a new business where an exquisite level of precision is required – machine tools for medical. Hanwha Precision Machinery will continue to work on creating innovative technology and advanced solution for our customers. Our value has been, and always will continue to be, centered on our customer - to enhance productivity, efficiency and quality.

## Business Area



### Machine Tool Division

Expert in CNC swiss lathes, centerless grinding, medical component tool and dental milling machine.



### SMT Division

Automated component mounting equipment for electronic circuit boards with single and high-mix production.

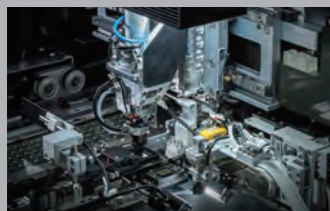

### Semiconductor Division

World's 1<sup>st</sup> front & back-end process equipment maker for AP, CPU and other semiconductors.

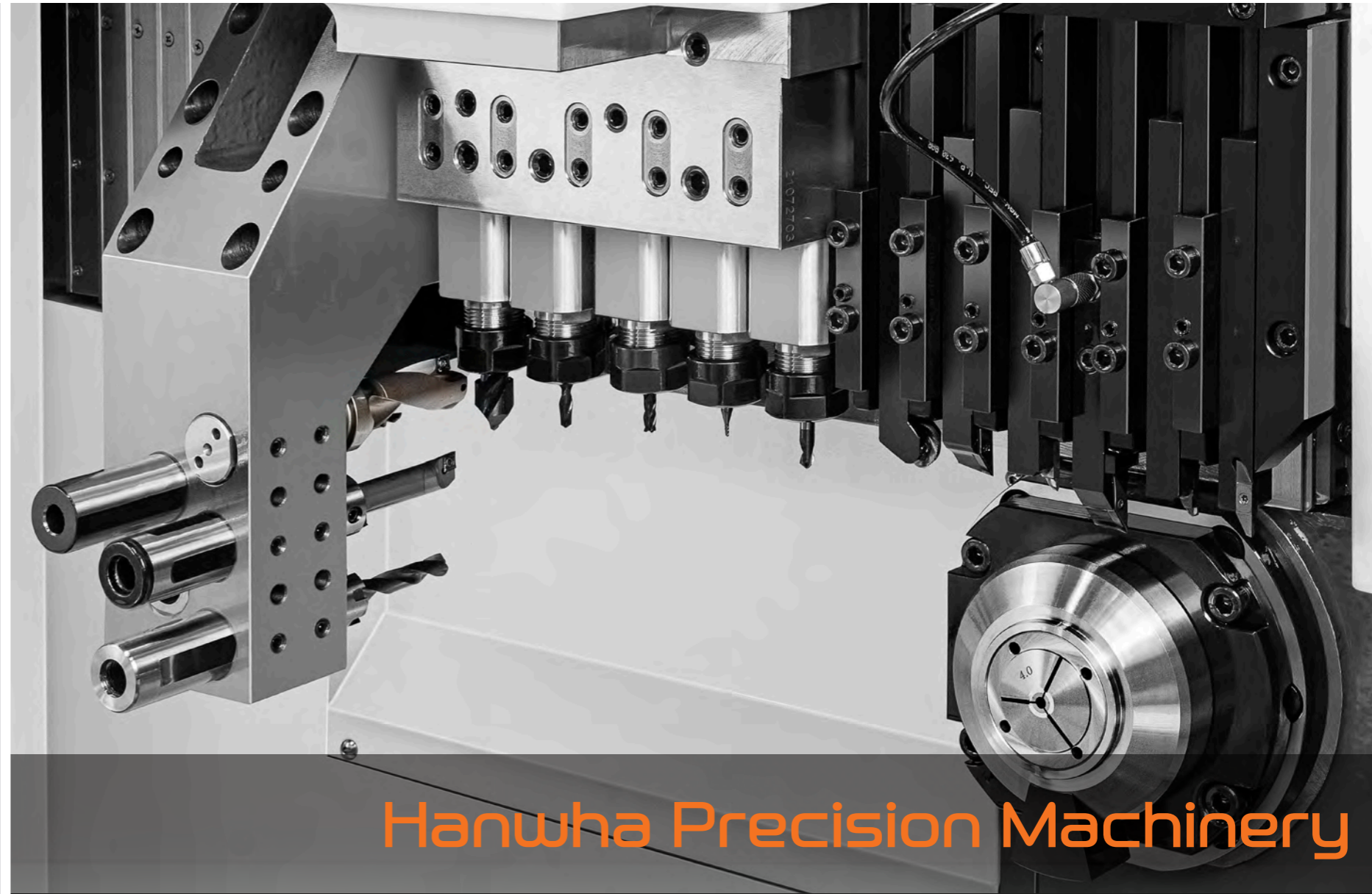

Hanwha Precision Machinery

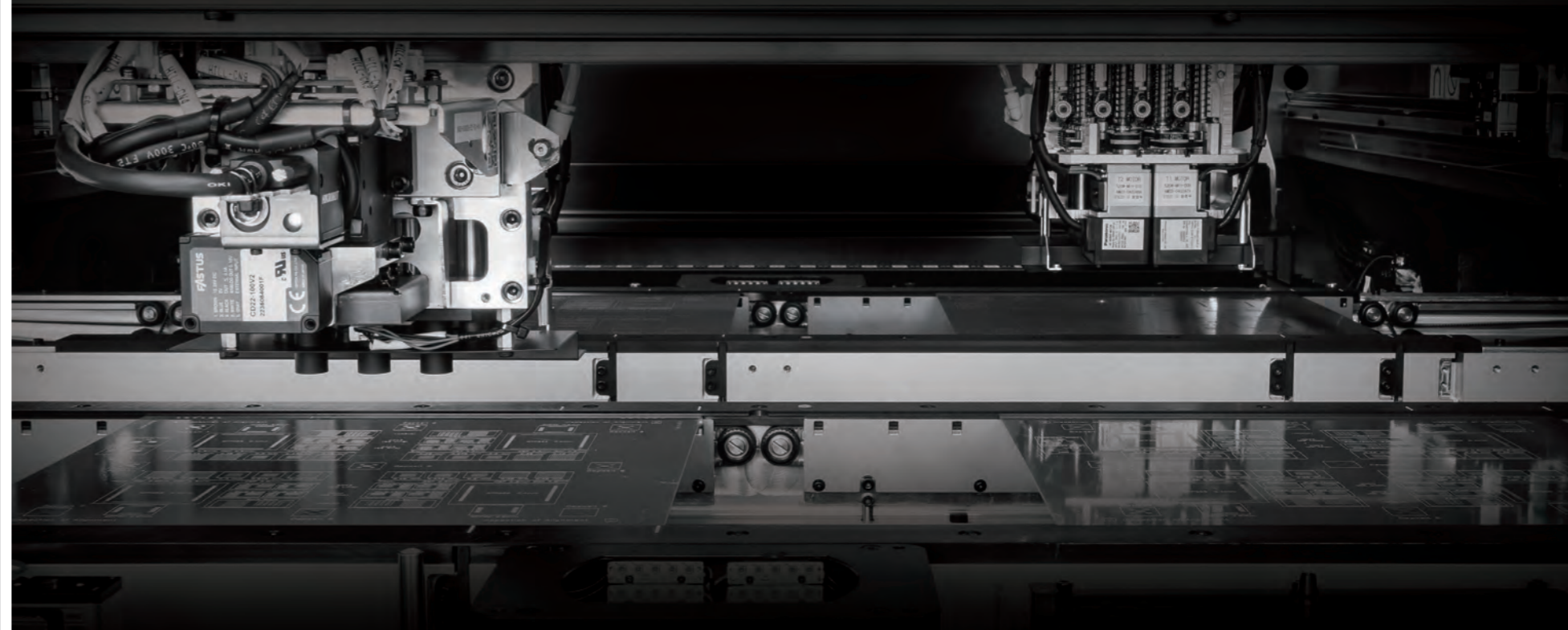



### CNC Swiss Turning Lathe

Optimized machine tool solution with a wide coverage from Ø10 to Ø 42mm, customizable with various options

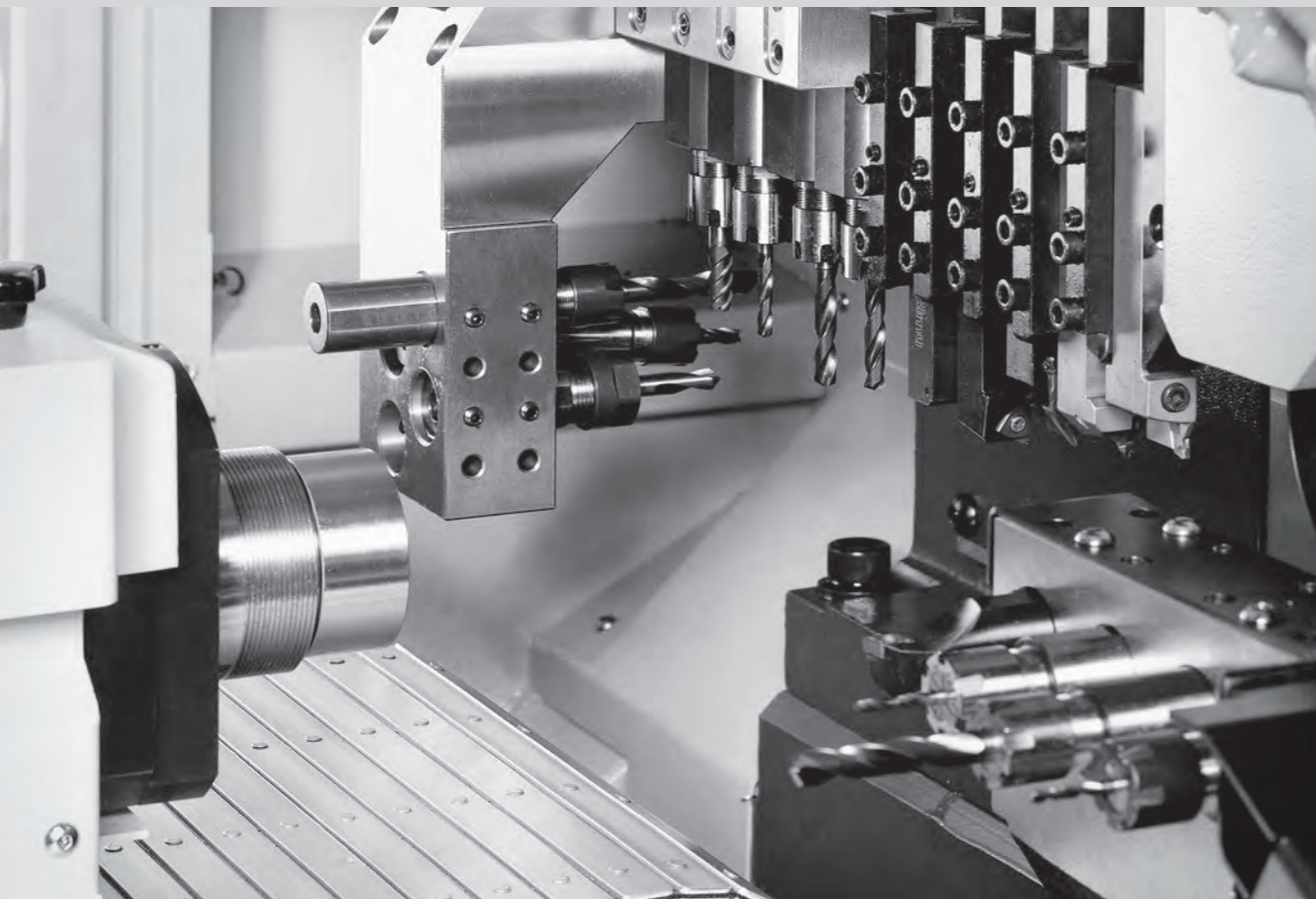

# Machine Tool Division

## "Machine of Machines", Now Shaping the Future

47 years of experience and expertise in Machine Tools helped us to become a manufacturing solution provider – who creates both equipment and software solution to enhance customer’s production experience. We will not stop moving forward to find a way to provide the best solution in machine tools. Our specialty in this business combined with our global networks around the globe will indeed help us to become the No. 1 in the market.

## To be the Global No.

47 Years of Expertise  
Sold over **30 Countries**





# STL42

Specialized 9-axis turret type sliding head machine with a powerful Siemens 840D controller (42mm)



Model	STL42	
	H	NH
NC	Siemens 840D	
Max. Machining Diameter (mm)	Ø42	
Z1 Stroke (mm)	420	282 (H), 125 (N)
Main Spindle	Speed (rpm)	6,000
	Motor (kW)	22
OD Tool	No. of Tools	5 (□20mm)
	No. of Tools	5 (ER20)
Cross Drill	Speed (rpm)	6,000
	Motor (kW)	2.59
Turret Unit	No. of unit	1 Unit (10 Station)
	No. of Tools	max. 30EA (□20mm, ER20)
	Tool type	VDI 30 (Option : BMT 45)
	Motor (kW)	2.59
Sub Spindle	Speed (rpm)	6,000
	Motor (kW)	22
Back Tool	No. of Tools	9 (ER20) (3 Fixed + 6 Driven)
	Speed (rpm)	6,000
	Motor (kW)	2.13
Machine Size (L x W x H) (mm)	3,580 x 2,060 x 1,980	
Weight (kg)	7,330	
Power Consumption (Cable Size) *	7.8kVA (Rated : 40kVA) (16SQ)	
Air Flow Rate (Liter/Min)	20 ~ 30 (Hydraulic device capacity : 30L)	

\* Based on Stainless Steel. May vary depending on machining condition.

## Dimension

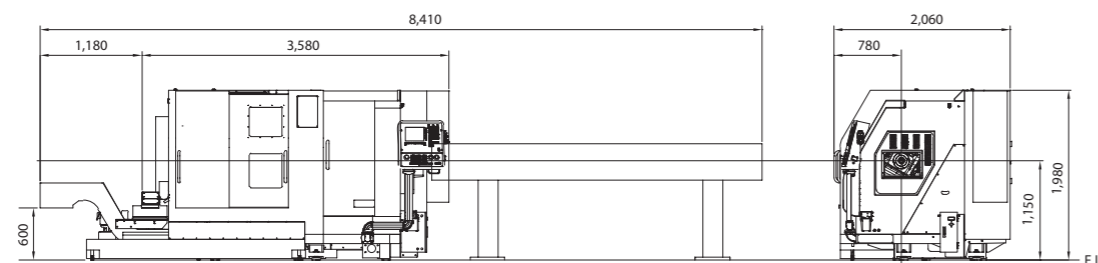

### OPTIMIZATION OF STRUCTURE & SPEC

Adopted built-in motor with hydraulic chucking cylinder for a strong chucking power

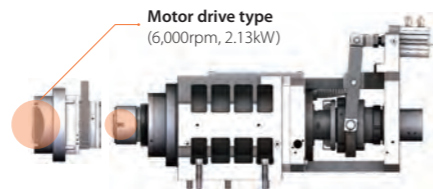

Motor drive type  
(6,000rpm, 2.13kW)

Unit	Spec
G/B	BRA-42
Chuck (Main, Sub)	TF48

### UPGRADED SOFTWARE PLATFORM

Provides a new HMI screen and improved software for machining & operating convenience



Tool Measuring

Collision Protection

## Option Tooling

Meets customer's need in high-mix machining work with ≤49 gang & turret tool posts & optimized tool for Ø42mm material

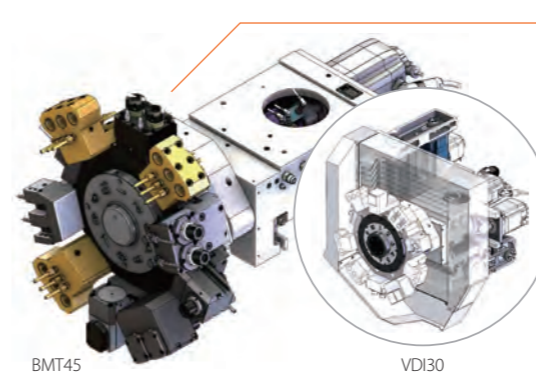

### Turret Unit

- Turret unit (selectable) : VDI (standard) or BMT (option)
- SRG (Roller Retainer) LM guide used to strengthen to transfer the turret unit.

#### Specification

- Driven : 6,000rpm, 2.59kW
- Tool Size : □20, ER20
- 10 Station
- Max. Number of Tools : 30
- Tool Holder Type : VDI30 (standard), BMT45 (option)

### Cross Drilling / Milling Unit

- Enhance productivity & optimization with large material by extending tool distance, using high-powered motor and increasing number of tools

#### Specification (STL38 → STL42)

- Tool Distance : 35mm → **60mm**
- Tool Spec : 4(ER20M) → **5(ER20)**
- Motor Spec : 6,000rpm, 1.07kW → **2.59kW**



### Back Tool Unit

- Expand machining range with Y3 axis feed & increased tool numbers
- Simultaneous on main & sub, as well as, high-complex machining possible with back tool cross unit (option)

#### Specification (STL38 → STL42)

- Tool Distance : 40mm → **60mm**
- Tool Spec : 8(ER20M) → **9(ER20)**
- Motor Spec : 6,000rpm, 1.07kW → **2.13kW**

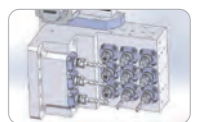

※ Back tool Cross unit (Option)  
→ No. of Tools : Back Tool 6, Cross 3

## COMPLEX MACHINING



Balance turning (OD+Turret)



Turning/drilling (OD+Turret)

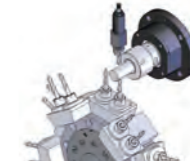

Endmill (Cross+Turret)



Drilling (Front+Back)

### Standard

- Main-Sub Cs control (0.001°)
- Rotary Guide bush holder
- MPG
- Chip conveyor
- Part conveyor
- Door interlock
- Work light
- Signal lamp (3color)
- Tool monitoring function
- Cut-off tool breakage detector (S/W)
- Auto power-off
- Bar feeder interface
- Middle pressure pump

### Option

- Bar feeder
- Transformer
- Tap breakage detector
- High pressure pump
- Oil mist collector
- Oil chiller
- Memory card
- Tooling & Programming
- Internal coolant-driven tool (cross, back, off-center)
- NC warranty for 2 years
- Turret unit (BMT45)
- Turret Tool Holder

# STL38

Turret type, sliding head machine (9-axis) with a powerful Siemens 840D controller

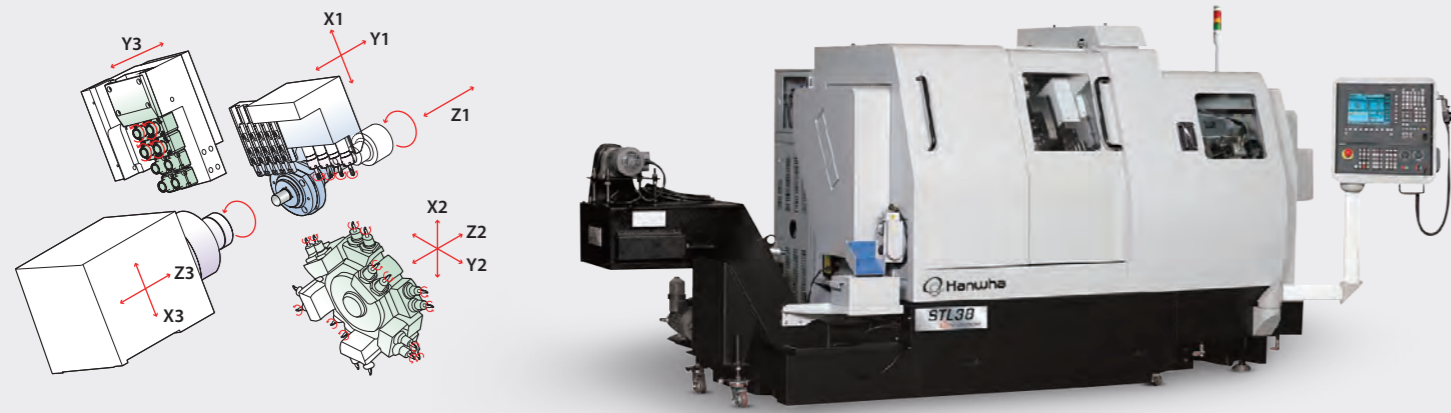

Model	STL32/38	
NC	Siemens 840D	
Max. Machining Diameter (mm)	Ø32/38	
Z1 Stroke (mm)	320	
Main Spindle	Speed (rpm)	6,500
	Motor (kW)	23
OD Tool	No. of Tools	5 (□16mm)
	No. of Tools	4 (ER20M)
Cross Drill	Speed (rpm)	6,000
	Motor (kW)	1.07
Turret Unit	No. of unit	1 Unit (10 Station)
	No. of Tools	max. 30 (□20mm, ER20)
	Tool type	VDI 30 (Option : BMT 45)
	Motor (kW)	2.59
Sub Spindle	Speed (rpm)	6,500
	Motor (kW)	23
Back Tool	No. of Tools	8 (ER20M) (4 Fixed + 4 Driven)
	Speed (rpm)	6,000
	Motor (kW)	1.07
Machine Size (L x W x H) (mm)	3,130 x 1,860 x 1,780	
Weight (kg)	4,500	
Power Consumption (Cable Size) *	7.7kVA (Rated : 40kVA) (16SQ)	
Air Flow Rate (Liter/Min)	20 ~ 30 (Hydraulic device capacity : 30L)	

\* Based on Stainless Steel. May vary depending on machining condition.

## COMPLEX MACHINING

Supports complex machining with a combination of gang & turret units and 3-path control system.

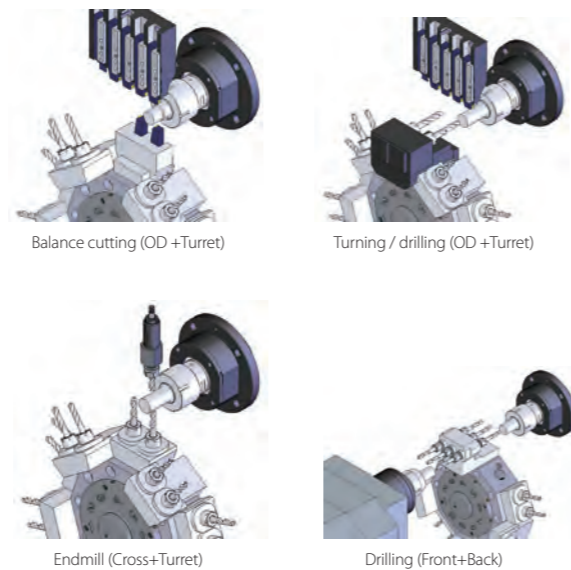

## Dimension

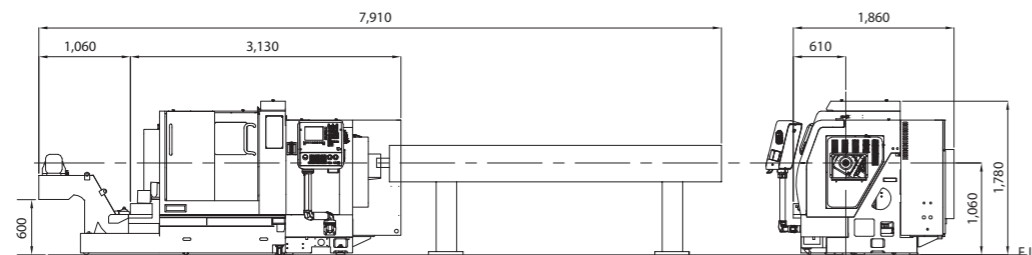

# Option Tooling

Customer optimized high-complex tooling is supported with ≤49 gang & turret tool posts and multiple layout options

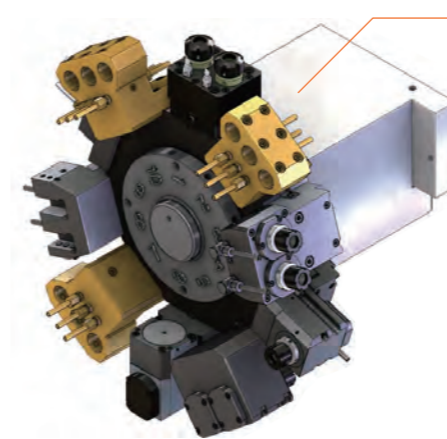

### Turret Unit

- Turret unit (selectable) : VDI (standard) or BMT (option)

#### Specification

- 1set Turret (10 station)
- Tool Holder Type : VDI30, BMT45
- Tool Size : □20, ER20
- Max. Number of Tools : 30

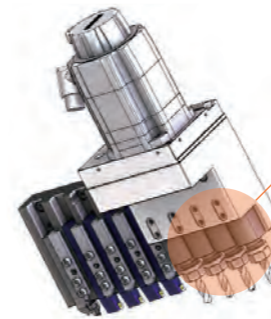
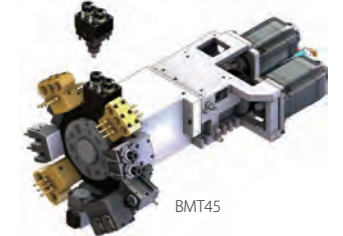
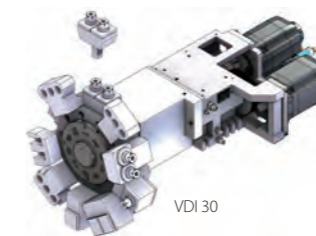

### Cross Drilling / Milling Unit

- Easy tool change for maintenance & installation

#### Option Tool



Internal coolant-driven tool  
※ Spline Modular

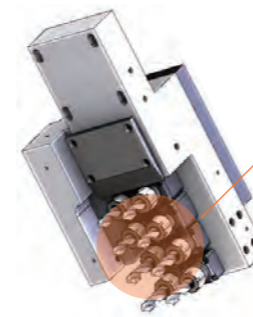

### Back Tool Unit

- Standard : Fixed 3 tool
- Modular Type : 8 tools of Y3 (4 driven, 4 fixed, ER20M)

#### Option tool & unit



Internal coolant-driven tool



Multi finger tool  
(Re-adjust machining point)



3 ~ 4 tools



8 tools  
(Max. 4 Driven)

## Standard

- Main-Sub Cs control (0.001°)
- Rotary Guide bush holder
- MPG
- Chip conveyor
- Part conveyor
- Door interlock
- Work light
- Signal lamp (3color)
- Tool monitoring function
- Cut-off tool breakage detector (S/W)
- Auto power-off
- Bar feeder interface
- Middle pressure pump

## Option

- Bar feeder
- Transformer
- Tap breakage detector
- High pressure pump
- Oil mist collector
- Oil chiller
- Memory card
- Tooling & Programming
- Internal coolant-driven tool (cross, back, off-center)
- NC warranty for 2 years
- Turret unit (BMT45)
- Turret Tool Holder

# XDI 26/32

3-path, 9-axis, independent opposite-gang tool machine for higher productivity & flexibility

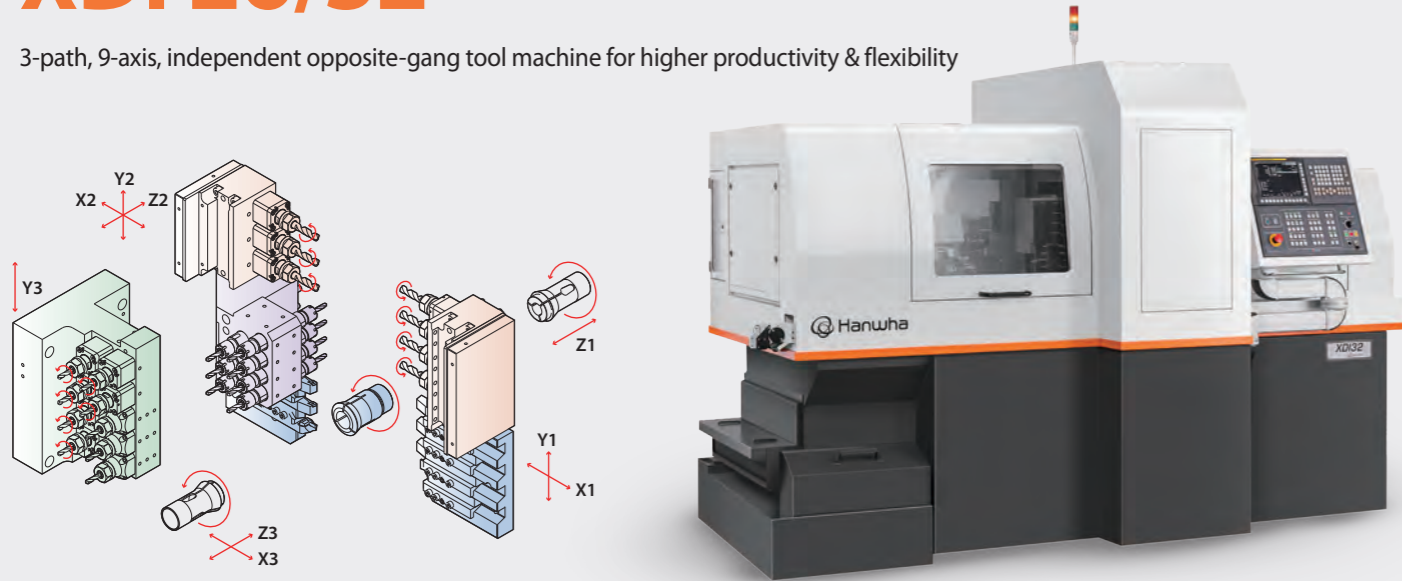

Model	XDI 26	XDI 32
NC	Fanuc - 31iB	
Max. Machining Diameter (mm)	Ø26	Ø32
Z1 Stroke / NH (mm)	350 (H), 100 (N)	
Main Spindle	Speed (rpm)	8,000
	Motor (kW)	2.2 / 5.5
Turning Tool	No. of Tools	□ 16mm x 7 (4 + 3)
	No. of Tools	ER16M x 4 (Front 4 / Rear 7)
Front Tool	No. of Tools	ER16 x 7 (4 + 3)
	Speed (rpm)	6,000
Cross Drill	Motor (kW)	1.0
	Motor (kW)	2.2
B-axis Cross (op.)	No. of Tools	ER16 x 4 (Front 4 / Rear 4)
	Speed (rpm)	6,000
Sub Spindle	Speed (rpm)	8,000
	Motor (kW)	2.2 / 5.5
Back Tool	No. of Tools	ER16 x 9 (Fixed 3 + Driven 6) (Option : Driven 6 + Cross 3 + Turning 2)
	Speed (rpm)	6,000
Machine Size (L x W x H) (mm)	Weight (kg)	6,300
	Power Consumption (Cable Size) *	4.3kVA (Rated : 13.5kVA) (16SQ)
Air Flow Rate (Liter/Min)	120 ~ 150	

\* Based on Stainless Steel. May vary depending on machining condition.

## VARIOUS SIMULTANEOUS MACHINING

Reduced cutting time with simultaneous machining by using the stand-alone opposite tool stage

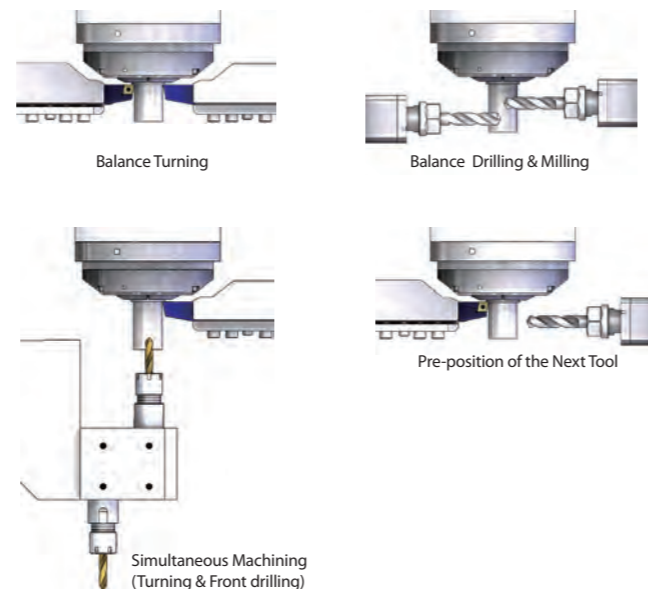

## DIMENSION

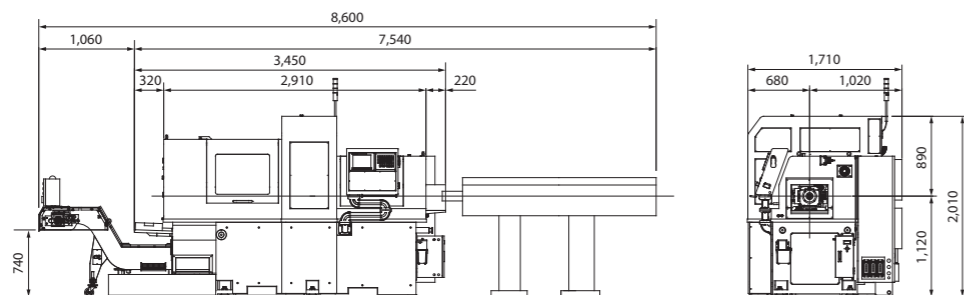

## Option Tooling

Provides flexible option tools for a higher productivity on complex machining

### Cross Drilling / Milling Unit

- Cross drill / Double-hinged B-axis Tool

#### Option Specification

- 4 cross drill (ER16, 1kW or 2.2 kW)
- The same cross modular with XD38II



Double-hinged B-axis tool (ER16x8, Front 4/Back 4)

- Motor Power : 1.0 kW
- Swivel Angle : -40° ~ +100°

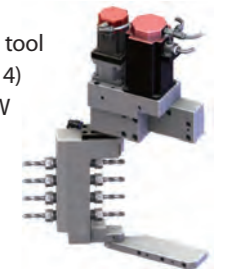

### Back Tool Unit

- Y3-axis 9 back tool / Y3-axis back tool cross

#### Option Specification

- Standard 9 back tool
- 6 Driven/3 Fixed Modular (ER16)
- Motor Power : 1.0 kW
- The same back tool modular with XD38II
- Whole gear-driven system



Option Y3-axis back tool cross

- 6 Back/3 Cross Modular (ER16)/ 2 Bite (□ 16)
- Motor Power : 1.0 kW
- The same back tool modular with XD38II
- Whole gear-driven system

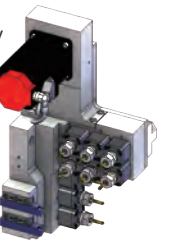

### Sub Gun Drill Unit

- 2 gun drills

- 2 gun drill (ER16)
- Max. drill length 190 mm

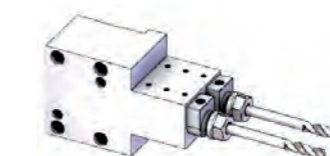

## Standard

- Main - Sub Cs control (0.001°)
- Rotary Guide bush holder
- Cross drilling · milling unit
- 2 MPG
- Door interlock
- Coolant flow sensor
- Work light
- Signal lamp (3color)
- LAN port
- Tool monitoring function
- Cut-off detector (S/W)
- Super imposed control
- Auto power-off
- Bar feeder interface
- Part conveyor

## Option

- Bar feeder
- Chip conveyor
- Extended coolant tank
- Transformer
- Tap breakage detector
- Pipe type ejection unit
- B-axis cross drill unit(4)
- Gun drill unit(2)
- Cross turning back tool post
- Middle / High pressure pump
- Oil mist collector
- Oil chiller
- Memory card
- Tooling & Programming
- Additional M-code
- Helical interpolation
- 3 dimension conversion
- NC warranty for 2 years

# XD42

Specialized 5/6-axis for larger diameter machining (≤42mm)



Model	XD42		
	H	N	NH
NC	Hanwha Fanuc-i		
Max. Machining Diameter (mm)	Ø42		
Z1 Stroke (mm)	320	100	207 (H), 100 (N)
Main Spindle	Speed (rpm)	6,000	
	Motor (kW)	5.5/7.5	
OD Tool	No. of Tools	5 (□20mm)	
Front Tool	No. of Tools	5 (ER20M, Ø32)	
Cross Drill	No. of Tools	4 (ER20M)	
	Speed (rpm)	6,000	
Off-Center Drill (Option)	Motor (kW)	2.2	
	No. of Tools	1 (ER20M)	
Sub Spindle	Type	Gear drive (Modular Type Drill)	
	Speed (rpm)	6,000	
Back Tool	Motor (kW)	2.2/5.5	
	No. of Tools	5 (ER20M) (3 Fixed + 2 Driven)	
Machine Size (L x W x H) (mm)	Speed (rpm)	6,000	
	Motor (kW)	1.0	
Weight (kg)	2,570 x 1,750 x 1,750		
Power Consumption (Cable Size) *	4,100		
Air Flow Rate (Liter/Min)	4.3kVA (Rated : 13.3kVA) (16SQ)		
	120 ~ 150		

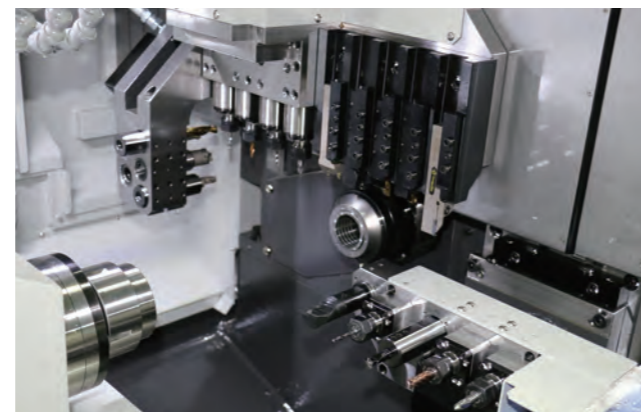

- Strong machining performance & high-productivity with large radii material
- Strong chucking force with hydraulic cylinder
- Improved bearing system for accuracy
- High rigidity of feed unit (with linear roller guide)

\* Based on Stainless Steel. May vary depending on machining condition.  
\* H : G/B, N : Non-G/B, NH : Convertible G/B

## Dimension

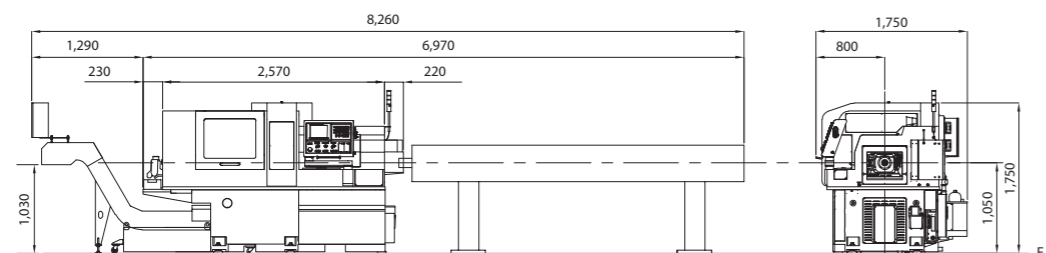

## Option Tooling

Offers flexible tool options to enhance productivity and to meet customer's needs

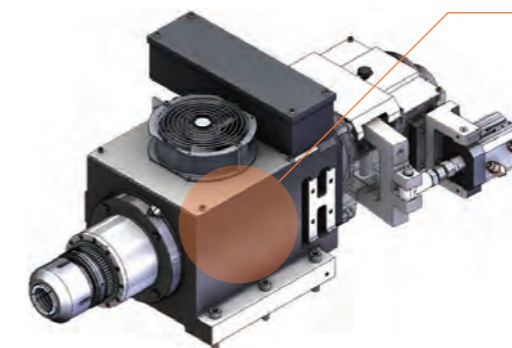

### Spindle Unit

- Adopted built-in motor, hydraulic chucking cylinder & 3 toggle system for a stronger chucking power to process Ø42mm material

**Specification**  
6,000 rpm  
5.5/7.5kW

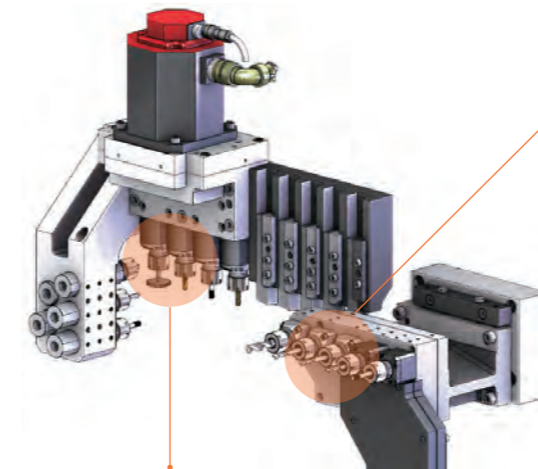

### Back Tool Unit

- Total of 8 tools with Y2-axis & modular type for an easy tool change and maintenance

**Specification**  
6,000rpm, 1.0kW  
5 tools (ER20M)

### Option tool



### Cross Drilling / Milling Unit

- Powerful cross-machining with the best-in-class motor and expanded tool size coverage
- Easy to change and maintain with a gear modular type cross unit and flexible option tool support

**Specification**  
6,000 rpm, 2.2kW  
4 Tools (ER20M)

### Selectable Modules on Back Tool

Max. 4 (driven)

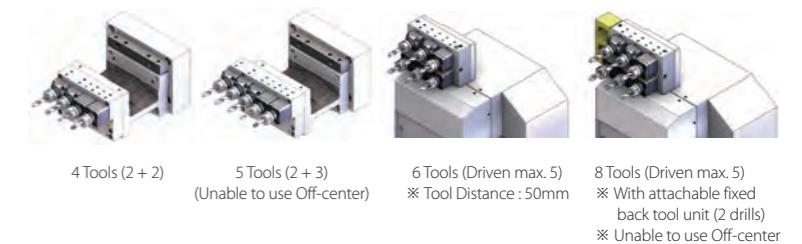

## Standard

- Main - Sub Cs control (0.001°)
- Rotary Guide bush holder
- Cross drilling · milling unit (4, Gear modular type)
- MPG
- Part conveyor
- Door interlock
- Coolant flow sensor
- Work light
- Signal lamp (3color)
- LAN port
- Tool monitoring function
- Cut-off tool breakage detector (S/W)
- Auto power-off
- Bar feeder interface

## Option

- Bar feeder
- Chip conveyor
- Transformer
- Tap breakage detector
- Pipe type ejection unit
- Off center drill unit (2)
- Middle / High pressure pump
- Oil mist collector
- Oil chiller
- Memory card
- Tooling & Programming
- Internal coolant-driven tool (cross, back, off-center)
- 3 Face/counterface-driven tool (cross)
- 3 Face/counterface angle-driven tool (cross)
- Extended coolant tank
- NC warranty for 2 years



# XD38II-R

The latest special heavy duty cutting/milling with 5/6-axis, Optimized for high-complexity (max. Ø38mm)

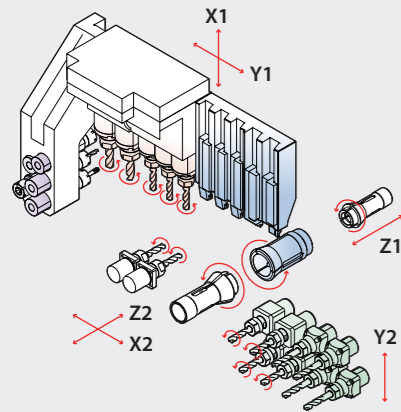

Model	XD38II-R	
NC	Fanuc 32i-B / Siemens 828D	
Max. Machining Diameter (mm)	Ø38 (Option : Ø40)	
Z1 Stroke (mm)	320 (H), 120 (N)	
Main Spindle	Speed (rpm)	6,500
	Motor (kW)	5.5/7.5 (Fanuc), 23 (Siemens)
OD Tool	No. of Tools	5 (□20mm x 2, □16mm x 3)
Front Tool	No. of Tools	5 (ER20M, Ø32)
	No. of Tools	5 (ER20 x 2, ER16 x 3)
Cross Drill	Speed (rpm)	6,000
	Motor (kW)	2.2 (Fanuc), 2.13 (Siemens)
Off-Center Drill (Option)	No. of Tools	2 (ER16) Modular
Sub Spindle	Speed (rpm)	6,500
	Motor (kW)	2.2/5.5 (Fanuc), 23 (Siemens)
Back Tool	No. of Tools	8 (ER16) (4 Fixed + 4 Driven)
	Speed (rpm)	6,000
	Motor (kW)	1.0 (Fanuc), 1.02 (Siemens)
Machine Size (L x W x H) (mm)	2,650 x 1,600 x 1,790	
Weight (kg)	4,600	
Power Consumption (Cable Size) *	3.7kVA (Rated: 14.6kVA) (16SQ) Siemens : 5.4kVA (Rated : 36kVA)	
Air Flow Rate (Liter/Min)	120 ~ 150	

\* Based on Stainless Steel. May vary depending on machining condition.  
\* NH : Convertible G/B

## OPTIMIZATION OF STRUCTURE & SPEC

### Specification of G/B & Chuck

Model	XD38II-R	XD38II
NC	Fanuc / Siemens	Fanuc
Type	NH	H/N/NH/He
Guide bush	BRA-42	TD38
Main chuck	TF48	TF44
Sub chuck	TF48	TF44

- Enhanced machining performance with the optimized structure, layout & expanded tool distance
- Easy switching between G/B & Non G/B
- Enhanced stroke, rigidity and chip disposal
- Flexible material feeding (bar feeder, automation unit & robot)

## Optimized Structure & Spec for Ø38mm

Possible to support ≤ Ø40mm (Option)

### Stroke

- Extended stroke & expanded processing area
  - Larger distance between tools
  - Support upper size tools
  - Extended stroke in Z1 on the convertible type G/B (G/B : 205mm → 320mm, Non-G/B : 80mm → 120mm)

Z1	X1	Y1	Z2	X2	Y2
320 (G/B) 120 (Non-G/B)	80	467 (+55*)	350 (+70*)	450 (+55*)	67.7

\* : increased stroke compared to XD38II

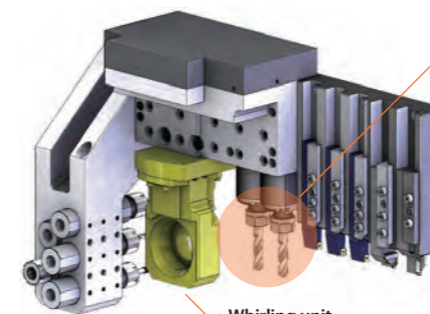

Whirling unit  
※ Other various option units are available

### Cross Drilling / Milling Unit

- Powerful cross machining
  - The best-in-class motor (Capacity : Fanuc 2.2kW, Siemens 2.13kW)
- Gear-driven modular
  - Easy to change and maintain with a gear modular type cross unit and flexible option tool support

#### Specification

6,000 rpm, 2.2kW (Fanuc), 2.13kW (Siemens)  
5 Tools (ER20 x 2, ER16 x 3)

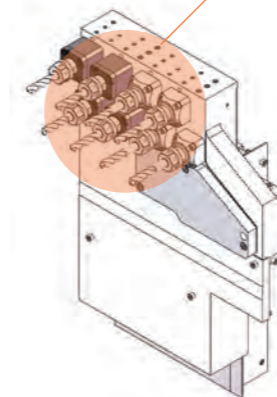

### Back Tool Unit

- Optimized structure for large material
- Extended tooling layout (Distance between tools : 52mm)
- Various option toolings
- Structure to have a less chip trouble

#### Specification

6,000 rpm, 1.0kW (Fanuc), 1.02kW (Siemens)  
8 Tools (4 Driven + 4 Fixed)

#### Option tool



Internal coolant driven tool



Back tool cross unit (Modular)

## Dimension

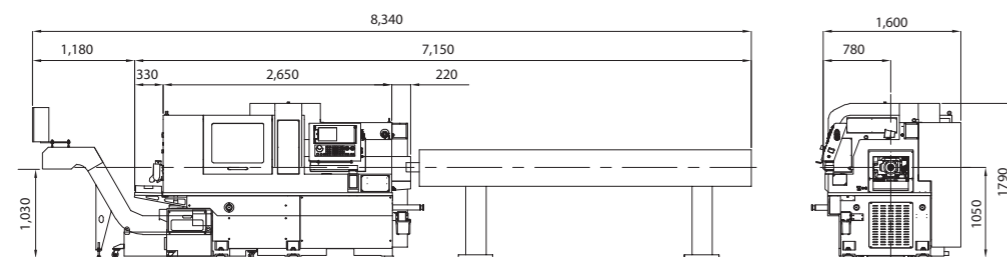

## Standard

- Main - Sub Cs control (0.001°)
- Rotary Guide bush holder
- Cross drilling · milling unit (5, Gear modular type)
- MPG
- Part conveyor
- Door interlock
- Coolant flow sensor
- Work light
- Signal lamp (3color)
- LAN port
- Tool monitoring function
- Cut-off tool breakage detector (S/W)
- Auto power-off
- Bar feeder interface

## Option

- Bar feeder
- Chip conveyor
- Right-way part conveyor
- Transformer
- Tap breakage detector
- Pipe type ejection unit
- Off center drill unit (2)
- Middle / High pressure pump
- Oil mist collector
- Oil chiller
- Memory card
- Tooling & Programming
- Internal coolant-driven tool (cross, back, off-center)
- 3 Face/counterface-driven tool (cross)
- 3 Face/counterface angle-driven tool (cross)
- Extended coolant tank
- NC warranty for 2 years

# XD38II

Specialized 5/6/7-axis for heavy duty cutting/milling

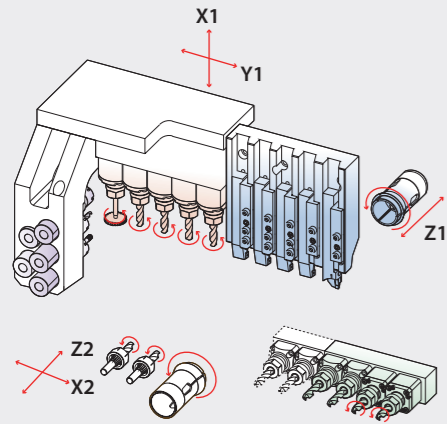

Model	XD32/38II			
	H	N	NH	He
NC	Fanuc 32i-B			Hanwha Fanuc-i
Max. Machining Diameter (mm)	Ø32/38			
Z1 Stroke (mm)	320	80	142 (H), 80 (N)	320
Main Spindle	Speed (rpm)	6,500		
	Motor (kW)	5.5/7.5		
OD Tool	No. of Tools	5 (□16mm)		
Front Tool	No. of Tools	5 (ER20M, Ø32)		
	No. of Tools	5 (ER16)		
Cross Drill	Speed (rpm)	6,000		
	Motor (kW)	2.2		
Off-Center Drill (Option)	No. of Tools	2 (ER16) Modular	2 (ER16) Non-modular	
	Type	Motor drive (6,000rpm, 1.0kW)	Gear drive	
Sub Spindle	Speed (rpm)	6,500 (Built-in motor)	6,500 (Spindle motor)	
	Motor (kW)	2.2/5.5	1.1/3.7	
Back Tool	No. of Tools	6 (ER16) (4 Fixed + 2 Driven)	4 (ER16) (2 Fixed + 2 Driven)	
	Speed (rpm)	6,000		
	Motor (kW)	1.0		
Machine Size (L x W x H) (mm)	2,570 x 1,440 x 1,740			
Weight (kg)	3,600			
Power Consumption (Cable Size) *	3.7kVA (Rated : 15.8kVA) (16SQ)			
Air Flow Rate (Liter/Min)	120 ~ 150			

\* Based on Stainless Steel. May vary depending on machining condition.  
 \* H : G/B, N : Non-G/B, NH : Convertible G/B, He : Hanwha Fanuc-i NC (with G/B)

## Dimension

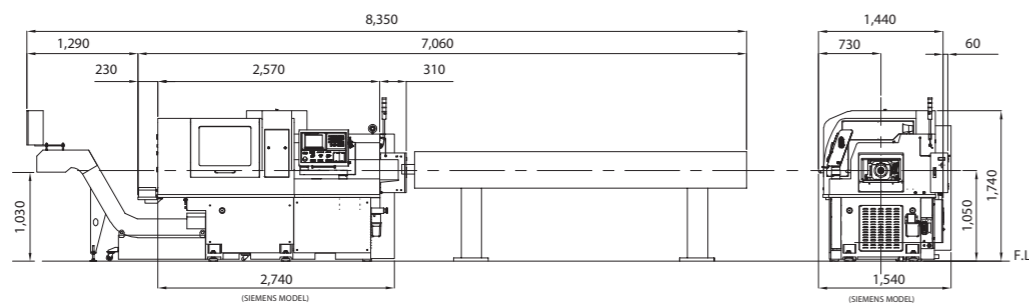

## OFF-CENTER UNIT

- 2 off-center drills with an individual motor
- No. of Tools : 2 (ER16)
- Speed & motor power: 6,500rpm, 1.0kW

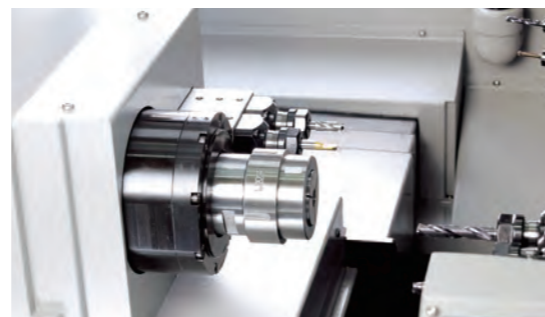

## Option Tooling

Customizable tooling layout and spindle structure to provide the most optimized solution for your machining condition & higher product quality

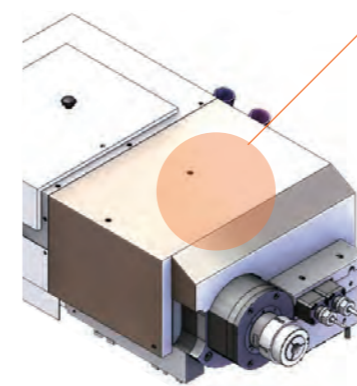

### Sub Spindle Unit

- Choice available between the powerful built-in motor and cost-effective spindle for Ø38mm
- ※ Possible to choose the motor type suitable for each material and production condition

Sub spindle		Spec	
Max. Machining Diameter		Ø38 mm	
Rotating Speed		6,500 rpm	
Motor Spec.	Built-in Motor	Fanuc 32i-B	2.2/5.5kW, 20/49Nm
	Spindle Motor	Hanwha Fanuc-i	1.1/3.7kW, 7/28Nm

### Back Tool Unit

- Total of 8 tools with Y2-axis & modular type for an easy tool change/maintenance

#### Option Unit

Attachable fixed drill unit  
Off-center available with 1 drill unit



#### Option Tool



#### Selectable Modules on Back Tool

Max. 4 (driven)



※ Option : Back tool cross unit (Modular)

## Standard

- Main-Sub Cs control (0.001°)
- Rotary Guide bush holder
- Cross drilling · milling unit (5, Gear modular type)
- MPG
- Part conveyor
- Door interlock
- Coolant flow sensor
- Work light
- Signal lamp (3color)
- LAN port
- Tool monitoring function
- Cut-off tool breakage detector (S/W)
- Auto power-off
- Bar feeder interface

## Option

- Bar feeder
- Chip conveyor
- Transformer
- Tap breakage detector
- Pipe type ejection unit
- Off center drill unit (2)
- Middle / High pressure pump
- Oil mist collector
- Oil chiller
- Memory card
- Tooling & Programming
- Internal coolant-driven tool (cross, back, off-center)
- 3 Face/counterface-driven tool (cross)
- 3 Face/counterface angle-driven tool (cross)
- Extended coolant tank
- NC warranty for 2 years

# XM20 eXcellent Medical Dental

Powerful 7-axis automatic lathe, specialized in dental products



Model	XM20	XM20 Y2	XM20 Y2+B
	NH		
NC	Fanuc 32i-B Plus		
Max. Machining Diameter (mm)	Ø20 (option : Ø25)		
Z1 Stroke (mm)	205 (H), 55 (N)		
Main Spindle	Speed (rpm)	10,000	
	Motor (kW)	2.2/3.7	
OD Tool	No. of Tools	6 (□12mm)	
	No. of Tools	3 (ER16)	
Cross Drill	No. of Tools	7 (4+3) (ER16)	3 (ER16)
	Speed (rpm)	6,000	
	Motor (kW)	2.5	
B-axis	No. of Tools	-	8 (ER11)
	Speed (rpm)	-	8,000
Sub Spindle	Speed (rpm)	10,000	
	Motor (kW)	2.2/3.7	
Back Tool Fixed : ER16 Driven : ER11	No. of Tools	4 (2 fixed + 2 driven)	8 (4 fixed + 4 driven)
	Speed (rpm)	9,000	
	Motor (kW)	1.0	
Machine Size (L x W x H) (mm)	2,160 x 1,200 x 1,900		
Weight (kg)	2,900	2,950	3,000
Power Consumption (Cable Size) *	3kVA (Rated : 7kVA) (10SQ)		
Air Flow Rate (Liter/Min)	62		

\* Based on Stainless Steel. May vary depending on machining condition.

### PRECISE & STABLE STRUCTURE

- High rigidity, low vibration structure with CAE technology
- Special structure to minimize thermal deformation
- Lighter tool post & Cooling jacket on spindle

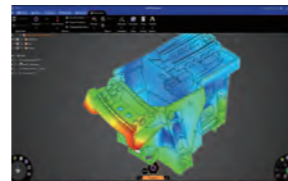

### CONVENIENT & ECONOMICAL MODEL

- Latest energy efficient technology (Energy Saving)
- Reduced maintenance cost by using common parts
- Improved convenience with mountable window cover & a large oil tank (208ℓ)

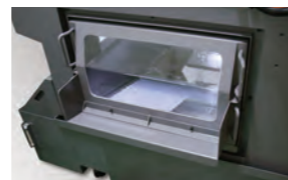

## Excellent Performance for Dental Products

Specially designed for dental parts : minimized thermal deformation while performing a stable and high-precision work.

### Cross Drilling / Milling Unit

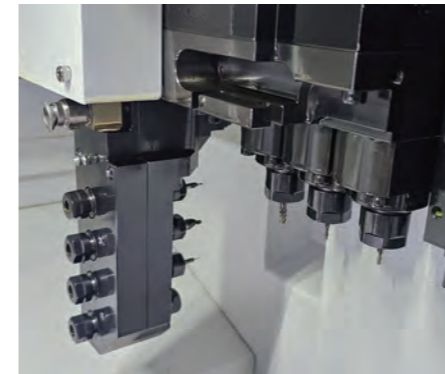

- Improved surface roughness and tool life with a high-performance, a high-efficient cross motor & NC 32iB Plus - all supporting to cut difficult materials
- Compatible with various option tools (4x modular, back cross, 3-axis live tool, etc.)
- High precision LM and B/S applied to improve roughness on taper processing

#### Option Specification

- Automatic B-axis cross drill unit
- ER16 x 3+ER11 x 8 (3+8)
- Motor power : 2.5kW
- Swivel angle : 0° ~ +90°

#### Standard Specification

- Manually adjustable, Side cross drill unit
- ER16 x 7 (4+3)
- Motor power : 2.5kW
- Angle : 0° ~ +135°



### Back Tool Unit

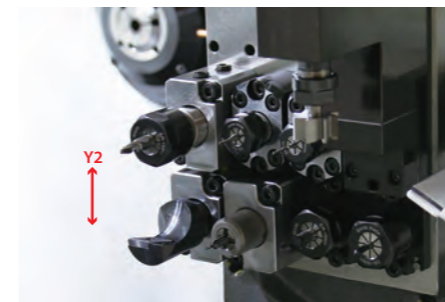

- High rigidity Y2 structure design
- Reduced lead-time on fixed-tool replacement by using a guide pin

#### Standard Specification

- 8 Back Tools
- 4 Fixed (ER16) / 4 Driven (ER11)
- Motor Power : 1.0kW
- Gear-Driven Modular

#### Option Specification

- 4 Back Tools
- 2 Fixed (ER16) / 2 Driven (ER11)
- Motor Power : 1.0kW

### Guide Bush



- NH (convertible guide bush)
- Easy setting for nozzle and tool

#### Z1 Stroke

- Guide bush 205mm
- Non Guide bush 55mm

### Sub Spindle & Off-Center Unit



- Powerful sub-spindle motor
- Sub-attached front tool

- Speed : 10,000rpm
- Motor power : 2.2/3.7kW
- Fixed tool : ER16 x 3



Screw    Fixture    Fixture    Temporary Abutment    Angle Abutment    Multi Angle Abutment    Abutment    Mount

### DIMENSION

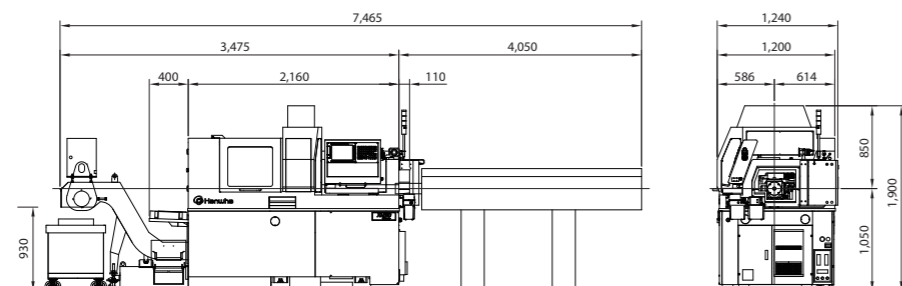

### Standard

- Main-Sub Cs control (0.001°)
- Rotary guide bush holder
- Cross drilling · milling unit (7, Gear modular type)
- Sub-attached 3-axis front tool (ER16)
- MPG
- Part receiver (Drawer type)
- Door interlock
- Coolant flow sensor
- Work light
- Signal lamp (3color)
- LAN port
- Tool monitoring function
- Cut-off tool breakage detector (H/W)
- Auto power-off
- Bar feeder interface

### Option

- Bar feeder
- Chip conveyor
- Transformer
- Modular type front tool holder
- Modular type OD tool holder
- Tap breakage detector
- Part conveyor
- Pipe type ejection unit
- Middle / High pressure pump
- Oil mist collector
- Oil chiller
- Memory card
- Tooling & Programming
- Extended coolant tank
- NC warranty for 2 years

# XD20/26II-V

Multi-functional with B and Y2-axis

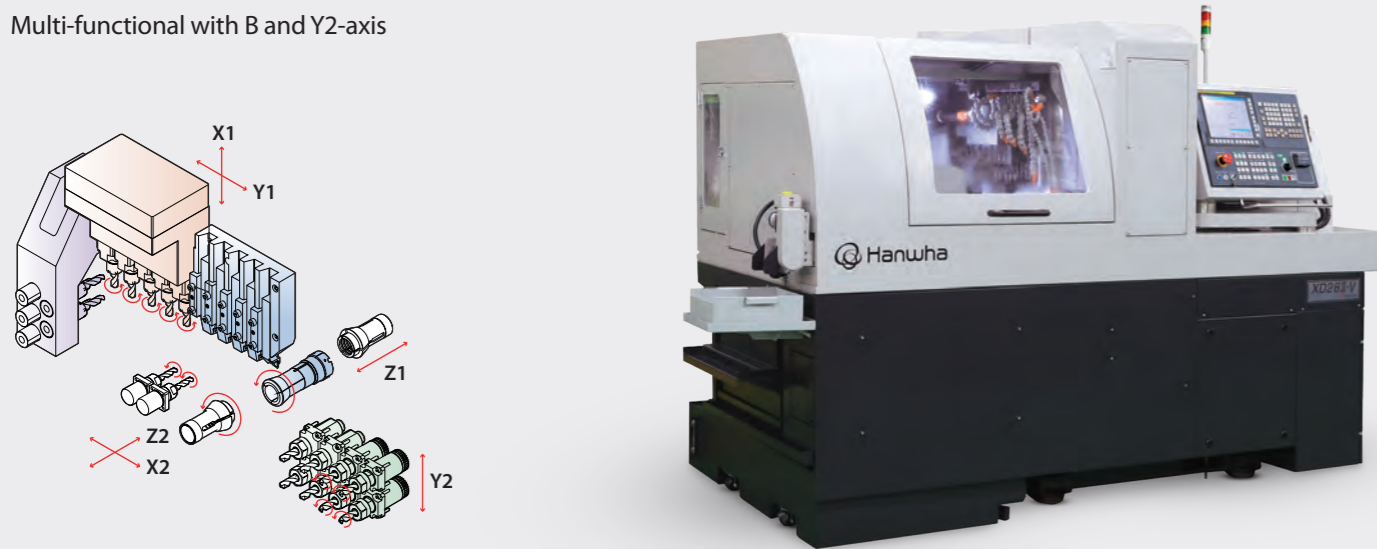

Model	XD20/26II-V		
	H	N	NH
NC	Fanuc 32i-B / Siemens 828D (B-axis 840D)		
Max. Machining Diameter (mm)	Ø20/26		
Z1 Stroke (mm)	210	50	210 (H), 50 (N)
Main Spindle	Speed (rpm)	10,000 (Ø20), 8,000 (Ø26)	
	Motor (kW)	Fanuc : 2.2/3.7 (Ø20), 2.2/5.5 (Ø26) Siemens : 14.4	
OD Tool	No. of Tools	6 (□12mm) (Ø20), 5 (□16mm) (Ø26)	
Front Tool	No. of Tools	5 (ER16M, Ø25)	
Cross Drill	No. of Tools	5 (ER16 (Ø20), ER16M (Ø26))	
	Speed (rpm)	6,000	
	Motor (kW)	1.0 (Fanuc), 1.02 (Siemens)	
Off-Center Drill (Option)	No. of Tools	2 (ER16) Modular	
Sub Spindle	Speed (rpm)	8,000	
	Motor (kW)	2.2/3.7 (Fanuc), 14.4 (Siemens)	
Back Tool	No. of Tools	8 (ER16) (4 Fixed + 4 Driven)	
	Speed (rpm)	6,000	
	Motor (kW)	1.0 (Fanuc), 1.02 (Siemens)	
Machine Size (L x W x H) (mm)	2,460 x 1,380 x 1,730		
Weight (kg)	2,900		
Power Consumption (Cable Size) *	4kVA (Rated : 7.7kVA) (10SQ)		
Air Flow Rate (Liter/Min)	120 ~ 150		

\* Based on Stainless Steel. May vary depending on machining condition.  
\* H: G/B, N: Non-G/B, NH: Convertible G/B

## OPTION TOOLING

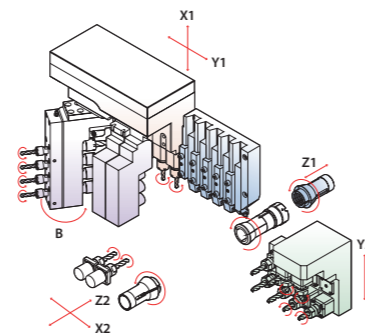

- Ultimate tooling capability with B-axis and Y2-axis
- Minimized thermal deformation with cooling system on cross drilling/milling unit
- Powerful built-in motor for main & sub-spindle (2.2/3.7kW(Fanuc), 14.4kW(Siemens))

## Option Tooling

Complex & productive machining for multi-shape parts with B-axis cross tooling and Y2-axis back tooling

### Cross Drilling / Milling Unit

- Cross unit with gear modular type for various tooling and an easy tool change / maintenance
- ※ Various option tool units : Triple speed rotating drill, Internal coolant-driven tool, 3 Face / counterface-driven tool, 3 Face / counterface angle-driven tool

#### Option Specification

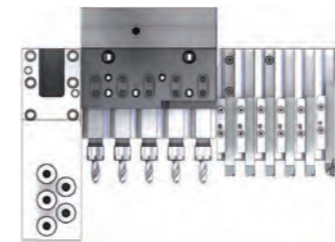

- Cross unit 5**
- OD 6 (□12)
  - Cross 5 (ER16)
  - Front 5 (ER16M)
  - ※ for XD20II-V

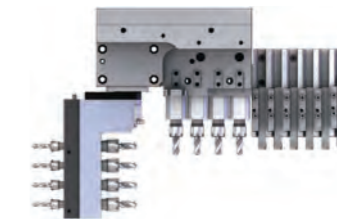

- B-axis Cross unit**
- OD 6 (□12)
  - Cross 4 (ER16)
  - B-axis 4 (ER16 x 4, ER11 x 4)
  - ※ for XD20II-V

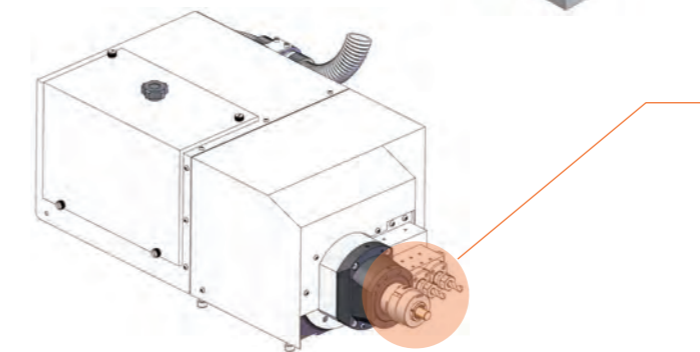
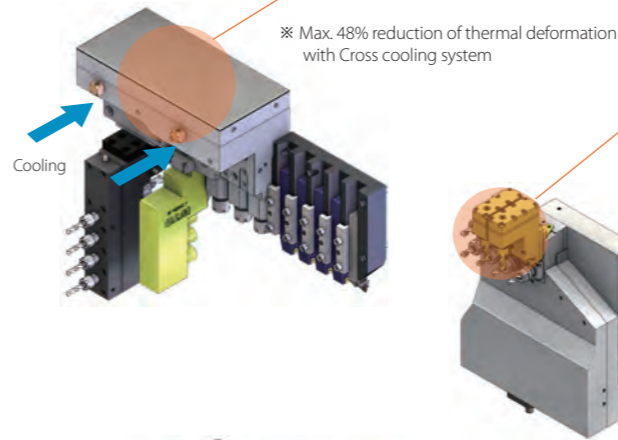

### Back Tool Unit

- Y2-axis tool post for flexible tooling
- Stable machining with enhanced structure & a powerful motor

#### Option Tool



Internal coolant driven tool



Back tool cross unit (Single body)



Back tool cross unit (Modular)

### Sub Spindle & Off-Center Unit

- Built-in motor on sub-spindle for a precision machining
- ※ 2 Off-Center Drill (Driven, Fixed) available

Feature	Value	
	Max. Machining Diameter	Ø20/26 mm
Rotation Speed	8,000 rpm	
Motor	2.2/3.7 kW (Fanuc)	
	14.4 kW (Siemens)	
Off-Center Drill Unit (Option)	Drill	2 (ER16)
	Type	Gear Modular

## Dimension

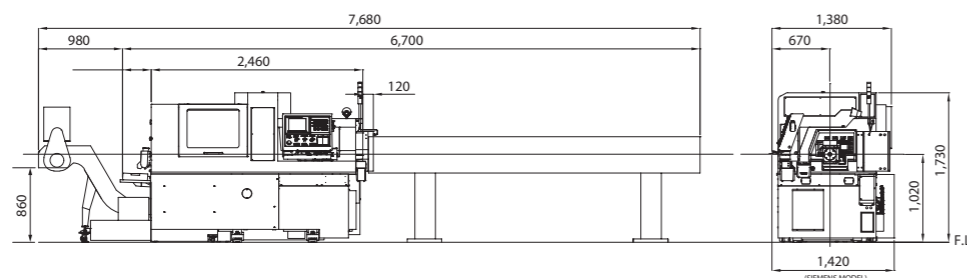

## Standard

- Main - Sub Cs control (0.001°)
- Rotary Guide bush holder
- Cross drilling · milling unit (5, Gear modular type)
- MPG
- Part conveyor
- Door interlock
- Coolant flow sensor
- Work light
- Signal lamp (3color)
- LAN port
- Tool monitoring function
- Cut-off tool breakage detector (S/W)
- Auto power-off
- Bar feeder interface

## Option

- Bar feeder
- Chip conveyor
- Transformer
- Tap breakage detector
- Pipe type ejection unit
- Off center drill unit (2)
- Middle / High pressure pump
- Oil mist collector
- Oil chiller
- Memory card
- Tooling & Programming
- Internal coolant-driven tool (cross, back, off-center)
- 3 Face/counterface-driven tool (cross)
- 3 Face/counterface angle-driven tool (cross)
- Extended coolant tank
- NC warranty for 2 years

# XD20/26III

The 3rd generation of Ø20/26, equipped with a powerful back tool unit (Y2)

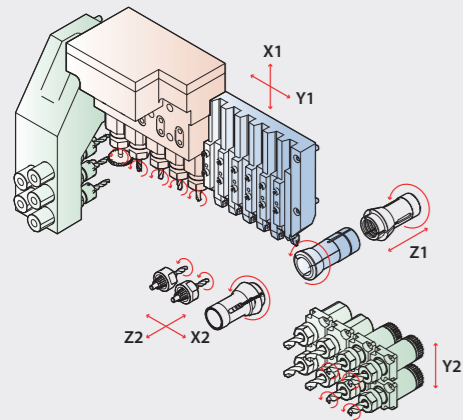

Model	XD20/26III	
	NH	
NC	Hanwha Fancu i / Siemens 828D	
Max. Machining Diameter (mm)	Ø20/26	
Z1 Stroke (mm)	H : 240, N : 60 (Ø20), 80 (Ø26)	
Main Spindle	Speed (rpm)	10,000 (Ø20), 8,000 (Ø26)
	Motor (kW)	Fanuc : 2.2/3.7 (Ø20), 2.2/5.5 (Ø26) Siemens : 16
OD Tool	No. of Tools	6 (□12mm) (Ø20), 5 (□16mm) (Ø26)
Front Tool	No. of Tools	5 (ER16M, Ø25)
Cross Drill	No. of Tools	5 (ER16) (Ø20), 5 (ER16M) (Ø26)
	Speed (rpm)	6,000
	Motor (kW)	1.0 (Fanuc), 1.02 (Siemens)
Off-Center Drill (Option)	No. of Tools	2 (ER16)
Sub Spindle	Speed (rpm)	8,000
	Motor (kW)	1.5/2.2 (Fanuc) , 2.59 (Siemens)
Back Tool	No. of Tools	8 (ER16) (4 fixed + 4 driven)
	Speed (rpm)	8,000
	Motor (kW)	1.0 (Fanuc), 1.02 (Siemens)
Machine Size (L x W x H) (mm)	2,460 x 1,290 x 1,750	
Weight (kg)	3,000	
Power Consumption (Cable Size) *	5.3kVA (Rated : 9kVA) (10SQ)	
Air Flow Rate (Liter/Min)	120 ~ 150	

\* Based on Stainless Steel. May vary depending on machining condition.

## ADVANTAGES

- Optimized & flexible machining for both long and short workpiece with a convertible guide bush unit. (standard)
- Extended stroke of Z1 240mm with a guide bush.



## Dimension

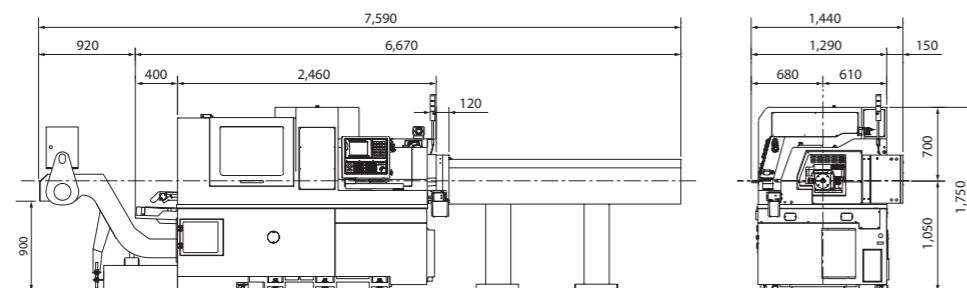

# Enhanced Machining Performance

Upgraded structure and performance with a wide range of options

## Cross Drilling / Milling Unit

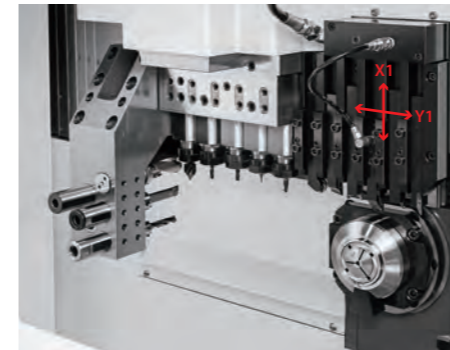

- Improved cross machining performance with an increased cross tools
- More powerful cutting with an enhanced motor power (option)

### Standard Specification

- 5 cross drills (ER16)
- Motor power : 1.0kW (Fanuc), 1.02kW (Siemens)
- The same cross-drill modular with XD20/26II

### Option Specification

- Powerful cross motor
- 5 cross drills (ER16)
- Motor Power : 2.2kW (Fanuc)
- The same cross-drill modular with XD20/26II

## Back Tool Unit

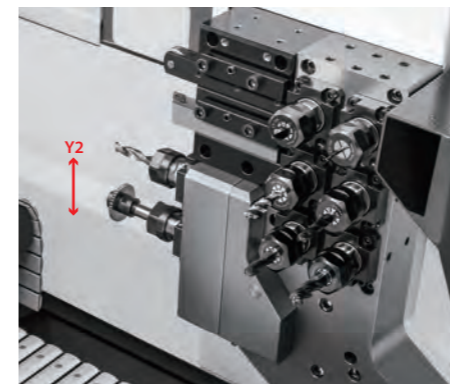

- Y2-axis 8 back tool / Y2-axis back cross tool

### Option Specification

- Back cross tools
- 6 back tools (6 driven) / 2 cross (ER16) / 3 turning (□12) (Ø20) or 2 turning (□16) (Ø26)
- Motor Power : 1.0kW (Fanuc), 1.02kW (Siemens)
- Gear-driven modular

### Standard Specification

- 8 back tools
- 4 fixed, 4 driven (ER16)
- ※ Option : Max 8 driven (ER16)
- Motor Power : 1.0kW (Fanuc), 1.02kW (Siemens)
- The same back modular with XD20/26II
- Gear-driven modular



## Sub-Spindle & Off-Center Unit



- Motor-driven, off-center drill sub-spindle

### Option Specification

- 2 off-center drill (ER16)
- Motor Power : 1.5/2.2kW (Fanuc), 2.59kW (Siemens)
- Gear-driven one body type

## Standard

- Main-Sub Cs control (0.001°)
- Rotary Guide bush holder
- Cross drilling · milling unit (5, Gear modular type)
- MPG
- Part conveyor
- Door interlock
- Coolant flow sensor
- Work light
- Signal lamp (3color)
- LAN port
- Tool monitoring function
- Cut-off tool breakage detector (S/W)
- Auto power-off
- Bar feeder interface

## Option

- Bar feeder
- Chip conveyor
- Transformer
- Tap breakage detector
- Pipe type ejection unit
- Off center drill unit (2)
- Middle / High pressure pump
- Oil mist collector
- Oil chiller
- Memory card
- Tooling & Programming
- Internal coolant-driven tool (cross, back, off-center)
- 3 Face/counterface-driven tool (cross)
- 3 Face/counterface angle-driven tool (cross)
- Extended coolant tank
- NC warranty for 2 years

# XD20/26II

The best selling 5-axis with max. Ø20/26mm

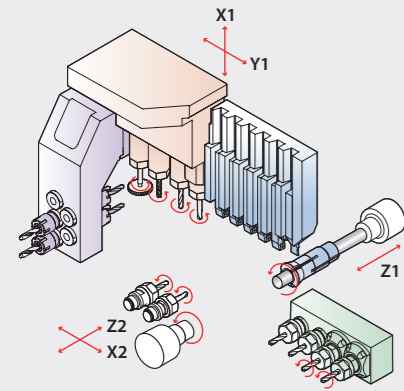

Model	XD20/26II			
	H	N	NH	M
NC	Fanuc 32i-B / Siemens 828D			
Max. Machining Diameter (mm)	Ø20/Ø26			
Z1 Stroke (mm)	210 (Fanuc), 240 (Siemens)	60mm	160 (H), 50 (N)	210
Main Spindle	Speed (rpm)	10,000 (Ø20), 8,000 (Ø26)		
	Motor (kW)	Fanuc : 2.2/3.7 (Ø20), 2.2/5.5 (Ø26) Siemens : 14.4		
OD Tool	No. of Tools	6 (□12mm) (Ø20), 5 (□16mm) (Ø26)		5 (□12mm)
Front Tool	No. of Tools	5 (ER16M, Ø25)		
	No. of Tools	4 (ER16 (Ø20), ER16M (Ø26))		5 (ER16M)
Cross Drill	Speed (rpm)	6,000		
	Motor (kW)	Fanuc : 1.0, Siemens : 1.02		
Off-Center Drill (Option)	No. of Tools	2 (ER16) Driven		2 (ER16M) Fixed long drill
	Speed (rpm)	8,000		
Sub Spindle	Motor (kW)	Fanuc : 1.5/2.2, Siemens : 2.59		
	No. of Tools	4 (ER16) (2 Fixed + 2 Driven)		
Back Tool	Speed (rpm)	6,000		
	Motor (kW)	Fanuc : 1.0, Siemens : 1.02		
Machine Size (L x W x H) (mm)	2,260 x 1,230 x 1,710			
Weight (kg)	2,700			
Power Consumption (Cable Size) *	2.5kVA (Rated : 6.9kVA) (10SQ)			
Air Flow Rate (Liter/Min)	120 ~ 150			



- Maximized tooling capability with various customizable options
- The best-suited for a precision and accuracy

\* Based on Stainless Steel. May vary depending on machining condition.  
\* H : G/B, N : Non-G/B, NH : Convertible G/B, M : Cross 5-axis+Long drills

## Dimension

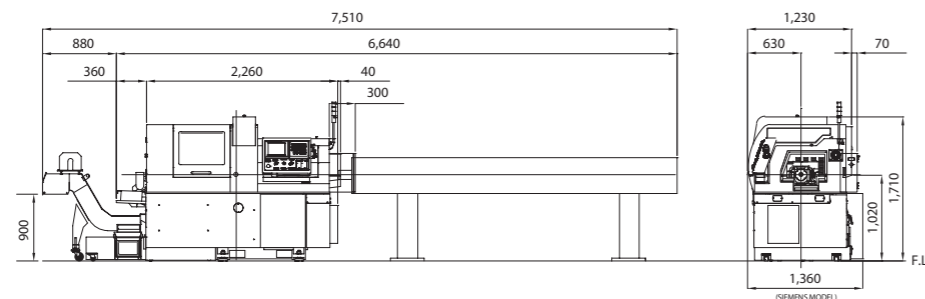

## Option Tooling

Offers a wide range of flexible tooling for a higher productivity and to cover customer's needs

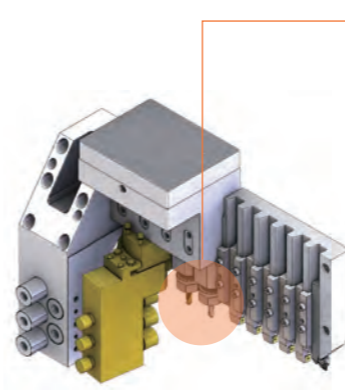

### Option Tool Layout

#### Cross Unit 4 (Standard)

- OD 6 (□12)
- Cross 4 (ER16)
- Front 5 (ER16M)

#### Cross Unit 5

- OD 5 (□16)
- Cross 5 (ER16M)
- Front 3 (ER16M)

#### Cross Unit 6

- OD 6 (□16 x 1, □11 x 5)
- Cross 6 (ER11M x 2, ER16 x 4)

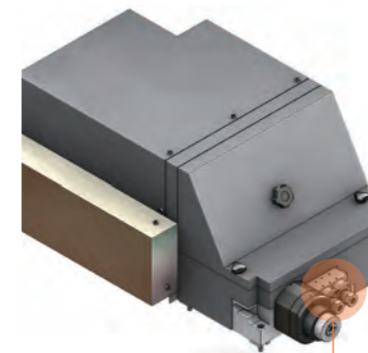
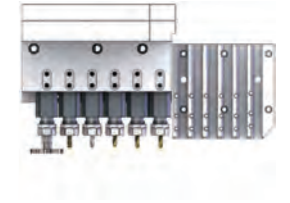
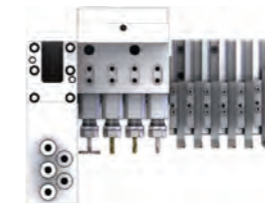

### Off-Center Unit

- Sub-spindle unit provides 2 driven drills or 2 fixed long drills for a deep hole machining (option)

#### Option tool

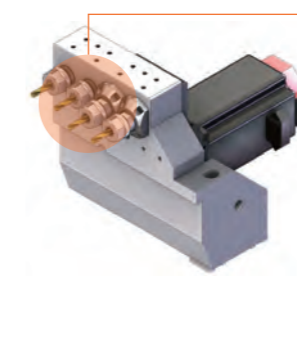

### Back Tool Unit

- Total of 6 tools as an option & a modular type for an easy tool change / maintenance

#### Option Unit Option Tool



#### Choice of Back Tool Modules

Max. 4 (driven)



※ Unable to use Off-center for 5 ~ 6 tools

## Standard

- Main-Sub Cs control (0.001°)
- Rotary Guide bush holder
- Cross drilling · milling unit (4, Gear modular type)
- MPG
- Part conveyor
- Door interlock
- Coolant flow sensor
- Work light
- Signal lamp (3color)
- LAN port
- Tool monitoring function
- Cut-off tool breakage detector (S/W)
- Auto power-off
- Bar feeder interface

## Option

- Bar feeder
- Chip conveyor
- Transformer
- Tap breakage detector
- Pipe type ejection unit
- Off center drill unit (2)
- Middle / High pressure pump
- Oil mist collector
- Oil chiller
- Memory card
- Tooling & Programming
- Internal coolant-driven tool (cross, back, off-center)
- 3 Face/counterface-driven tool (cross)
- 3 Face/counterface angle-driven tool (cross)
- Extended coolant tank
- NC warranty for 2 years

# XE35

Reliable 5-axis model with max. Ø35mm

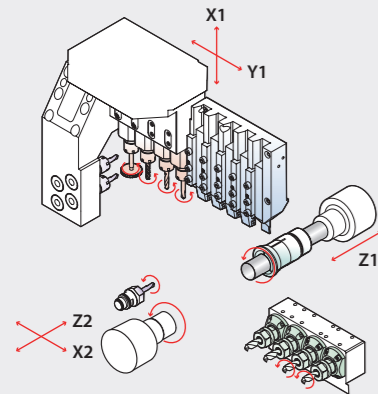

# XE20/26

Reliable 5-axis model with max. Ø20/26mm

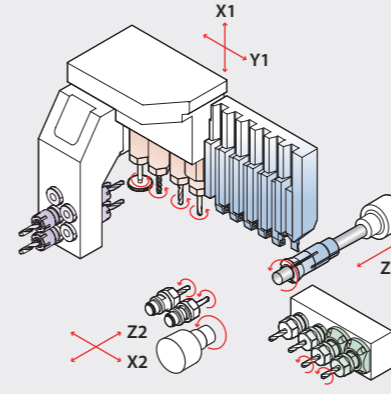

Model	XE35			
	H	N	J	Ne
NC	Hanwha Fanuc-i			
Max. Machining Diameter (mm)	Ø35			
Z1 Stroke (mm)	210	60	210	60
Main Spindle	Speed (rpm)	6,500		
	Motor (kW)	2.2/5.5		
OD Tool	No. of Tools	5 (□16mm)		
Front Tool	No. of Tools	4 (ER16M, Ø25)		
	No. of Tools	4 (ER16M)		
Cross Drill	Speed (rpm)	6,000		
	Motor (kW)	1.0		
Off-Center Drill (Option)	No. of Tools	1 (ER16)		
Sub Spindle	Speed (rpm)	6,500		
	Motor (kW)	1.5/2.2		
Back Tool	No. of Tools	4 (ER16) (2 Fixed + 2 Driven)	4 (ER16) (4 Fixed)	
	Speed (rpm)	6,000		
	Motor (kW)	1.0		
Machine Size (L x W x H) (mm)	2,050 x 1,490 x 1,760			
Weight (kg)	2,750			
Power Consumption (Cable Size) *	2.2kVA (Rated : 6.9kVA) (10S)			
Air Flow Rate (Liter/Min)	120 ~ 150			

\* Based on Stainless Steel. May vary depending on machining condition.  
 \* H : G/B & Driven back tool(2), J : G/B & Fixed back tool  
 \* N : Non-G/B & Driven back tool(2), Ne : Non-G/B & Fixed back tool

### OPTION TOOLING

#### Cross Unit 5

- OD 5 (□12)
- Cross 5 (ER16M)
- Front 5 (ER16M)

※ Cross (standard): Spline modular type  
 ※ Option : 3 Face/counterface-driven tool,  
 3 Face/counterface angle-driven tool

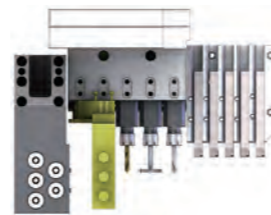

Model	XE20/26				
	H	N	NH	J	Ne
NC	Hanwha Fanuc-i				
Max. Machining Diameter (mm)	Ø20/26				
Z1 Stroke (mm)	210	60	160 (H), 50 (N)	210	60
Main Spindle	Speed (rpm)	10,000 (Ø20), 8,000 (Ø26)			
	Motor (kW)	2.2/3.7 (Ø20), 2.2/5.5 (Ø26)			
OD Tool	No. of Tools	6 (□12mm) (Ø20), 5 (□16mm) (Ø26)			
Front Tool	No. of Tools	5 (ER16M, Ø25)			
	No. of Tools	4 (ER16)			
Cross Drill	Speed (rpm)	6,000			
	Motor (kW)	1.0			
Off-Center Drill (Option)	No. of Tools	2 (ER16)			
Sub Spindle	Speed (rpm)	8,000			
	Motor (kW)	1.5/2.2			
Back Tool	No. of Tools	4 (ER16) (2 Fixed + 2 Driven)	4 (ER16) (4 Fixed)		
	Speed (rpm)	6,000			
	Motor (kW)	1.0			
Machine Size (L x W x H) (mm)	2,260 x 1,240 x 1,670				
Weight (kg)	2,500				
Power Consumption (Cable Size) *	2.2kVA (Rated : 6.9kVA) (10SQ)				
Air Flow Rate (Liter/Min)	120 ~ 150				

\* Based on Stainless Steel. May vary depending on machining condition.  
 \* H : G/B & Driven back tool(2), J : G/B & Fixed back tool  
 \* N : Non-G/B & Driven back tool(2), Ne : Non-G/B & Fixed back tool, NH : Convertible G/B & Driven back tool(2)

### OPTION TOOLING

#### Cross Unit 5

- OD 5 (□16)
- Cross 5 (ER16M)
- Front 3 (ER16M)

#### Cross Unit 6

- OD 6 (□16 x 1 + □11 x 5)
- Cross 6 (ER11M x 2, ER16 x 4)

※ Option : 3 Face/counterface-driven tool,  
 3 Face/counterface angle-driven tool

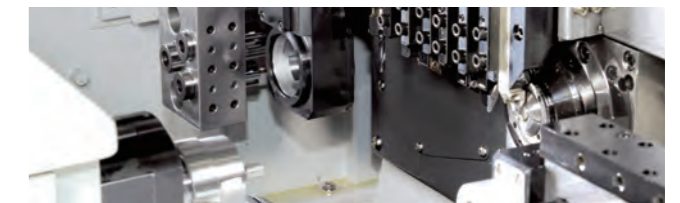
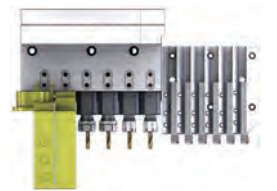

### Dimension

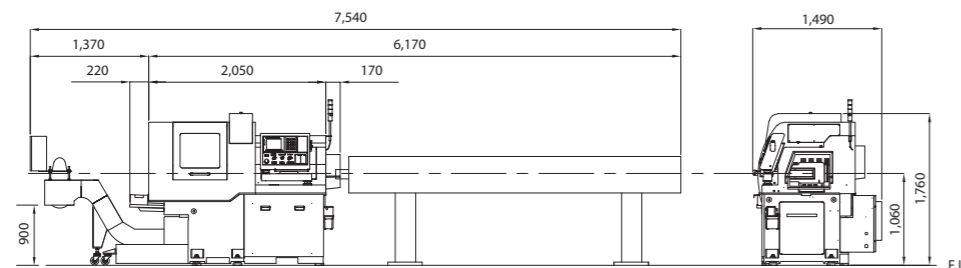

### Dimension

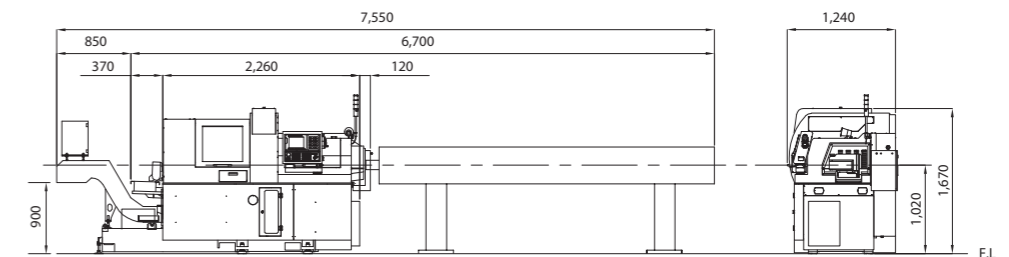

# XD16III

High-speed 5-axis solution for max. Ø16mm

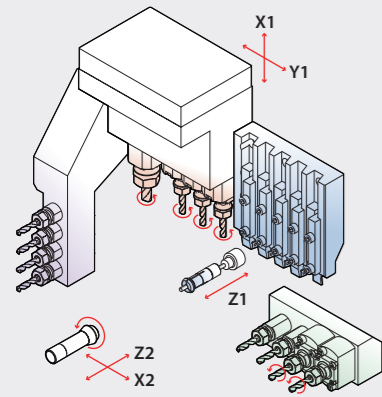

# XD10

High productivity & precision 5/6-axis solution for max. Ø10mm

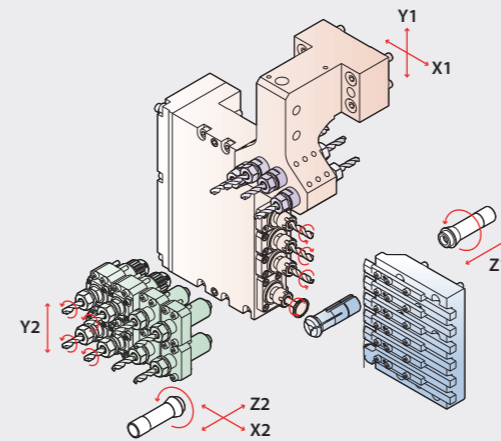

Model	XD16III	
	H	J
NC	Hanwha Fanuc-i	
Max. Machining Diameter (mm)	Ø16	
Z1 Stroke (mm)	155	
Main Spindle	Speed (rpm)	15,000
	Motor (kW)	2.2/3.7
OD Tool	No. of Tools 5 (□ 12mm)	
Front Tool	No. of Tools 4 (ER11, Ø20)	
	No. of Tools 4 (ER11 x 3 + ER16 x 1)	
Cross Drill	Speed (rpm)	6,000(ER16), 9,000(ER11)
	Motor (kW)	1.0
	Long Drill (Option)	No. of Tools 1 (ER11) drilling depth : 76.5mm
Sub Spindle	Speed (rpm)	10,000
	Motor (kW)	0.55/1.1
Back Tool	No. of Tools	4 (ER11) (2 Fixed + 2 Driven)
	Speed (rpm)	9,000
	Motor (kW)	1.0
Machine Size (L x W x H) (mm)	1,700 x 1,190 x 1,670	
Weight (kg)	2,200	
Power Consumption (Cable Size) *	1.8VA (Rated : 5.6kVA) (10SQ)	
Air Flow Rate (Liter/Min)	120 ~ 150	

\* Based on Stainless Steel. May vary depending on machining condition.  
\* H : G/B & Driven back tool(2), J : G/B & Fixed back tool

## OPTION TOOLING

**Cross Unit 5 (modular 2)**  
• ER11 x 3, Modular ER16 x 2

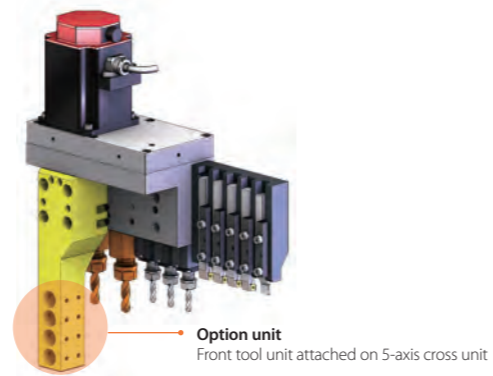

- Fast cycle time
- High speed spindle (Main : 15,000 rpm, Sub : 10,000 rpm)
- Great machining performance with a strong motor power on back tool (Capacity : 1.0 kW)

Model	XD10	
	Hanwha Fanuc-i	
NC	Hanwha Fanuc-i	
Max. Machining Diameter (mm)	Ø10	
Z1 Stroke (mm)	155	
Main Spindle	Speed (rpm)	15,000
	Motor (kW)	2.2/3.7
Turning Tool	No. of Tools □ 8mm x 6	
Front Tool	No. of Tools ER11 x 4	
	No. of Tools ER11M x 4 (Option: ER11M x 5)	
Cross Drill	Speed (rpm)	10,000
	Motor (kW)	0.55
Sub Spindle	Speed (rpm)	10,000
	Motor (kW)	0.55 / 1.1
Back Tool	No. of Tools	ER11 x 8 (Y2: Fixed 4 + Driven 4) (Option: Fixed 2 + Driven 2)
	Speed (rpm)	9,000
	Motor (kW)	0.55
Machine Size (L x W x H) (mm)	1,810 x 1,150 x 1,770 (W type : 1,810 x 970 x 1,850)	
Weight (kg)	2,200	
Power Consumption (Cable Size) *	1.8VA (Rated : 5.6kVA) (10SQ)	
Air Flow Rate (Liter/Min)	120 ~ 150	

\* Based on Stainless Steel. May vary depending on machining condition.

## OPTION TOOLING

**Whirling Tool**  
• ER11M x 2  
• Modular Whirling x 1

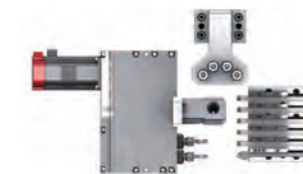

**Cross Unit 4 (Modular 1)**  
• ER11M x 3  
• Modular ER11M x 1

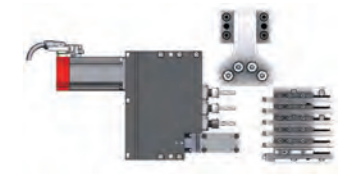

**Back Tool 8 (Max. 4/Driven)**  
• ER11 x 8

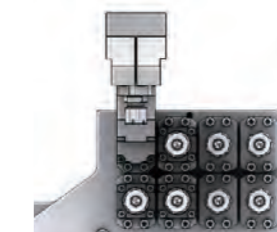

**Back Tool 4 (Max. 4/Driven)**  
• ER11 x 4

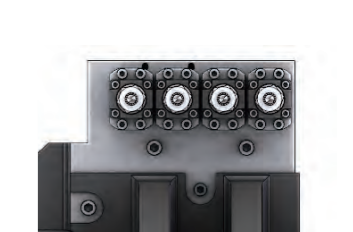

## Dimension

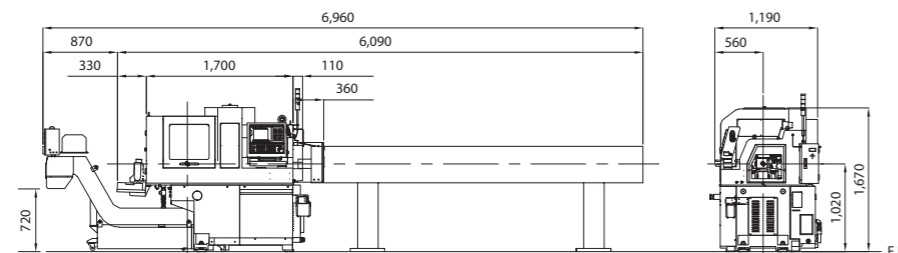

## Dimension

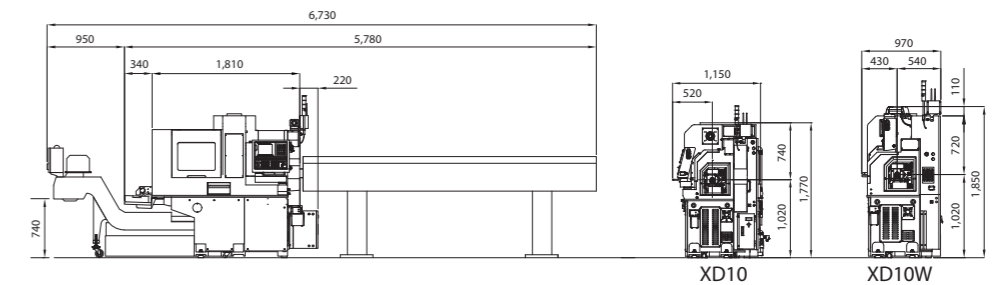



# XP20/26/32S

Compact, cost-efficient 4-axis model for max. Ø20/26/32mm (with a side cross tool)

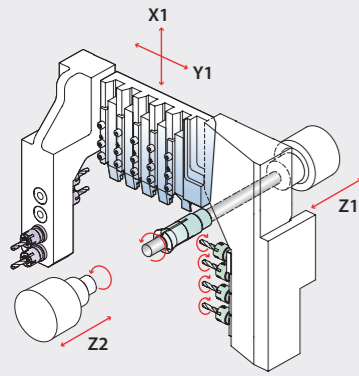

# XP12/16S

Compact & cost efficient 4-axis model for max. Ø12/16mm

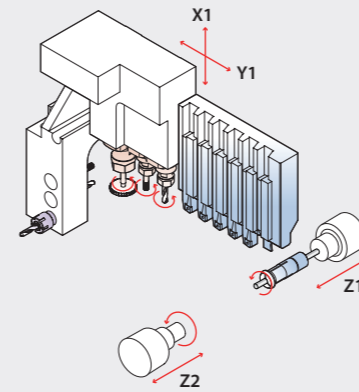

Model	XP20S	XP26S	XP32S	
NC	Hanwha Fanuc-i			
Max. Machining Diameter (mm)	Ø20	Ø26	Ø32	
Z1 Stroke (mm)	210	205		
Main Spindle	Speed (rpm)	8,000		
	Motor (kW)	2.2/3.7	5.5/7.5	
OD Tool	No. of Tools	6 (□12mm)	5 (□16mm)	
	No. of Tools	4 (ER16M, Ø25)		
Cross Drill	Speed (rpm)	6,000	5,000	
	Motor (kW)	1.0		
Sub Spindle	Speed (rpm)	8,000		
	Motor (kW)	0.55/1.1	1.5/2.2	
Machine Size (L x W x H) (mm)	2,030 x 1,140 x 1,710			
Weight (kg)	2,300	2,500		
Power Consumption (Cable Size) *	2.2VA (Rated : 4.7kVA) (10SQ)	2.2VA (Rated : 9.5kVA) (16SQ)		
Air Flow Rate (Liter/Min)	120 ~ 150			

### OPTION TOOLING

#### Cross Unit 4 (1 modular)

- ER16M x 4
- ※ Cross (standard) : Non-modular

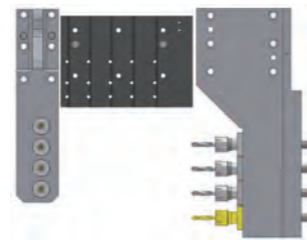

- Perfect for an old cam lathe user who seek a higher precision and productivity
- A long-runner with a proven record of performance & production quality

### Dimension

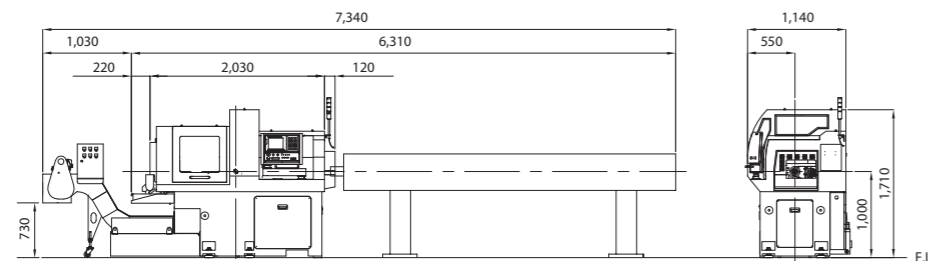

Model	XP12S	XP16S
NC	Hanwha Fanuc-i	
Max. Machining Diameter (mm)	Ø12	Ø16
Z1 Stroke (mm)	140	
Main Spindle	Speed (rpm)	12,000
	Motor (kW)	2.2/5.5
OD Tool	No. of Tools	6 (□12mm)
	No. of Tools	3 (ER11, Ø20)
Cross Drill	Speed (rpm)	6,000
	Motor (kW)	0.5
Sub Spindle	Speed (rpm)	8,000
	Motor (kW)	0.55/1.1
Machine Size (L x W x H) (mm)	1,650 x 1,090 x 1,640	
Weight (kg)	1,800	
Power Consumption (Cable Size) *	1.8VA (Rated : 3.9kVA) (10SQ)	
Air Flow Rate (Liter/Min)	120 ~ 150	

### OPTION TOOLING

#### Cross Unit 4

- OD 5 (□12)
- Cross 4 (ER16 x 1, ER11 x 3)
- Front 3 (ER11)

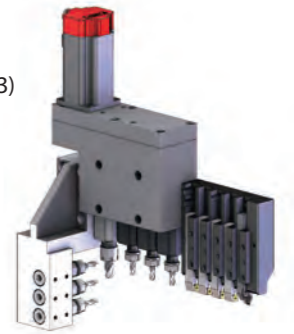

#### Gear-Hobbing Unit

- Maker : Pibomulti
- Angle : -2° ~ 2°

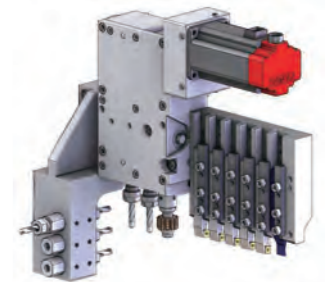

### Dimension

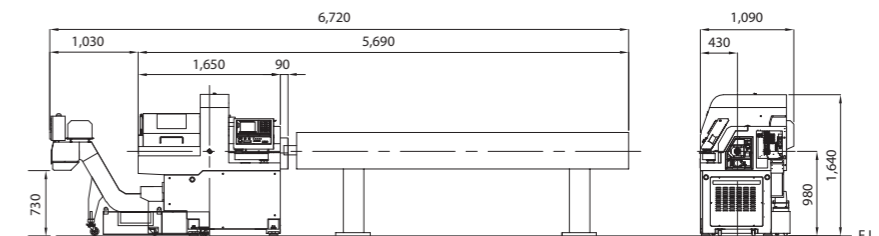

# Options

Your customizable choice in option units to enhance performance, productivity and convenience

Standard & Option Accessory		STL42	STL38	XDI 26/32	XD42	XD38II-R	XD38II	XD20/26II-V	XD20/26III		XM20	XD20/26II	XD16III	XD10	XE35	XE20/26	XP20/26/32S	XP12/16S	
Off-cent unit	Driven(2)	-	-	★	★(1)	★	★	★	★		N/A	★	-	-	★(1)	★	-	-	
	Fixed (Long drill, 2)	-	-	★	-	★(1)	★(1)	★	▲		★	★	★(1)	-	-	★	-	-	
	Off-center tailstock	-	-	▲	★	★	★	★	▲		★	★	-	-	★	★	-	-	
Internal coolant-driven unit	Cross	★	★	★	★	★	★	★	★		★	★	★(Modular)	▲	★	★	-	-	
	Back	★	★	★	★	★	★	★	★		★	★	-	▲	★	★	-	-	
	Off-center	-	-	▲	★	★	★	★	★		★	★	-	-	★	★	-	-	
Fixed angle drilling unit	Cross, 1	★	★	★	★	★	★	▲	★		▲	▲	-	-	▲	▲	-	-	
	Back, 1	★	★	★	★	★	★	▲	★		▲	▲	-	▲	▲	▲	-	-	
Option tool unit	Triple speed cross drill	★	★	▲	★	★	★	★	★		★(4x Speed)	★	★(Modular)	▲	★	★	-	-	
	Triple speed reduction cross drill	★	★	▲	★	★	★	★	★		▲	★	★(Modular)	▲	★	★	-	-	
	3 Face/counterface-driven tool	★	★	▲	★	★	★	★	★		★	★	-	-	★	★	-	-	
	3 Face/counterface angle-driven tool	★	★	▲	★	★	★	★	★		★	★	-	-	★	★	-	-	
	Gear hobbing	★(Turret)	★(Turret)	▲	★	★	★	★	★		★	★	▲	▲	★	★	-	★	
	Whirling	★	★	▲	★	★	★	★	★		★	★	★	-	★	★	-	-	
	Side cutter	★(Turret)	★(Turret)	▲	★	★	★	★	★		★	★	★	★	★	★	-	-	
	Back tool cross (Modular)	Vertical(Y2)	-	-	★	★	★	★	★	▲		★	-	-	★	-	-	-	-
		Horizontal	-	-	★	★	★	★	★	▲		-	★	-	★	-	-	-	-
	Option Unit	B-axis cross unit	-	-	★	-	-	-	★	-		Standard	-	-	-	-	-	-	-
Back tool cross unit		★(Y3)	-	Standard	-	-	-	★	★		-	-	-	▲	-	-	-	-	
Coolant unit	Chiller integrated High pressure coolant pump	★	★	★	★	★	★	★	▲		★	★	★	★	★	★	★	▲	
	Extended coolant tank	-	-	★	★	★	★	★	▲		▲	★	★	★	★	★	★	★	
Chip conveyor	Standard chip conveyor	-	-	★	★	★	★	★	★		★	★	★	★	★	★	★	★	
	Smart chip conveyor	-	-	▲	★	★	★	★	▲		★	★	-	-	-	★	-	-	
	Lower type chip conveyor	★	★	▲	★	★	★	★	▲		★	★	★	-	★	★	★	★	

★: Option ▲: Discussable -: N/A

# Special Accessories

**Swing Gripper**

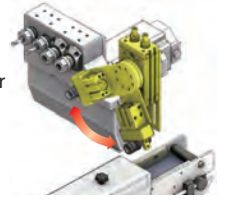

Gripper fingers grip and release finished parts onto the conveyor belt for ejection

- Application Example :  
Vulnerable material, Long parts

• XD20/26II, XD38II, XD42, XE20/26

**Auto-Loading Parts Unit**



Auto loader for a forged or diecasted part to supply via the main spindle door

• XD20/26II, XD38II, XD42, XE20/26

**Auto-Stacking Unit for Machined Parts**



Auto-loader for ejected parts onto the stacking pallet

• XD38II

# Tooling Variation

## XD20/26III

- Front/Back Tool
- Cross Drill
- Special Option Tool
- OD Tool

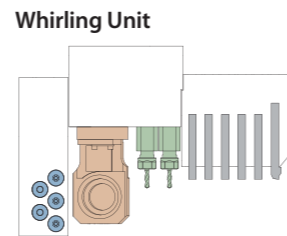
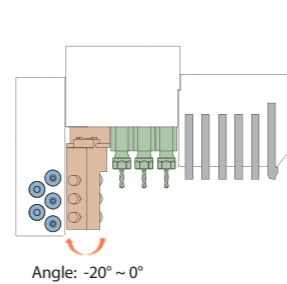
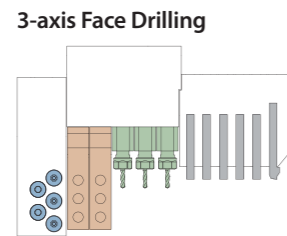
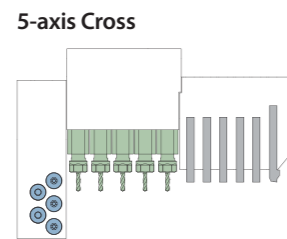

## XD38II

- Front/Back Tool
- Cross Drill
- Special Option Tool
- OD Tool

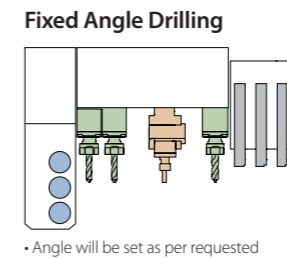
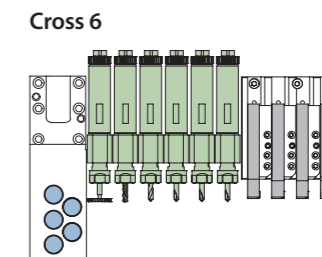
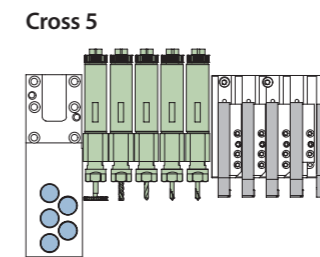

## Back Tool Option Unit

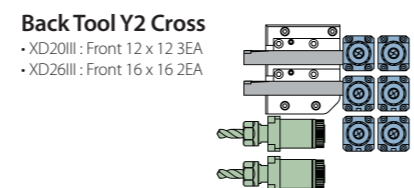
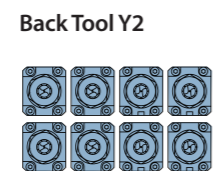
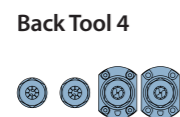

## Back Tool Option Unit (Y2)

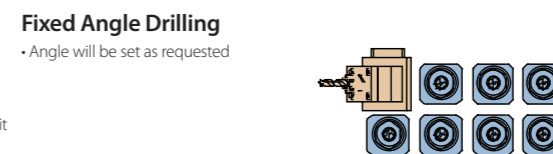

※ When a special tool is installed, the back tool unit should have max. 4 tools  
 ※ Back tool option is available on both 6(Y2) and 8(Y2)

# Hi-CPS Hanwha Intelligence CNC Prognostic System



- Enable customers to manage factory in a smart & convenient way by providing a real-time monitoring on machine status
- Based on a Cloud system for an easier access with a simple internet service

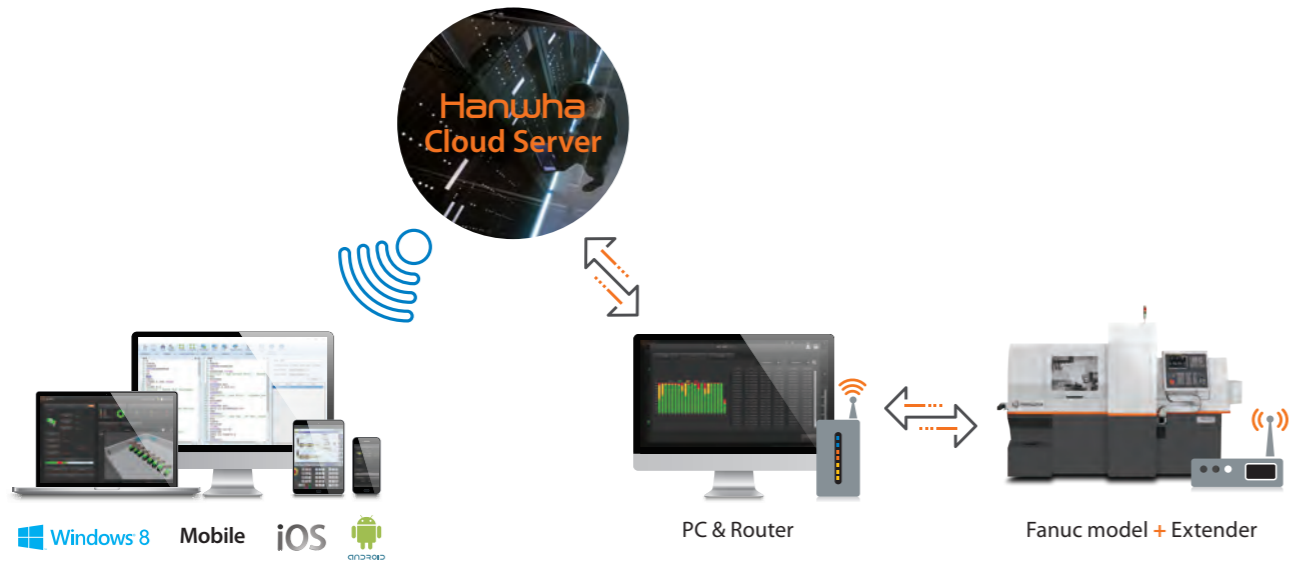

<p><b>Man Power &amp; Cost Reduction</b></p>	<p><b>Management Efficiency Increase</b></p>	<p><b>Productivity &amp; Quality Increase</b></p>	<p><b>Minimize Down time</b></p>
<p><b>MONITORING</b> Possible to monitor and control all machines in real-time away from the production line with a PC &amp; Mobile devices</p>	<p><b>DIAGNOSIS</b> A simple click on "Request for Diagnosis" to request S/W alarm diagnostics - no need to make an additional report</p>	<p><b>PROGNOSIS</b> A remote control to input offset value, transfer and modify programs without a direct access to the machine</p>	<p><b>PRE-NOTIFY</b> Minimize machine down-time with forecasted notification before a machine stop from a simple tool wearing-off or an error</p>

# PCR III Programmable Chip Removal



## Hanwha's Chip Control Technology

- Solves chip troubles from spiraling, entangling or piling-up around cutting tool edges
- Enhanced quality of machined surface with the finishing mode

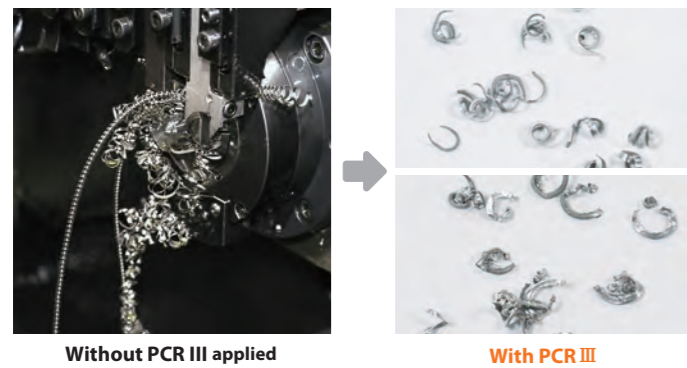

- |   |  |
|---|--|
| <p><b>Advantage</b></p> <ul style="list-style-type: none"> <li>• Better tool life</li> <li>• Build-up edge free</li> <li>• Chip trouble free</li> <li>• Coolant usage saved</li> <li>• Reduced chip volume</li> </ul> | <p><b>Applied Process</b></p> <ul style="list-style-type: none"> <li>• Front turning, drilling &amp; boring</li> <li>• Back turning, drilling</li> <li>• Taper, circular interpolation</li> <li>• Synchronous control</li> <li>• Threading</li> <li>• Nose R compensation</li> </ul> |
|---|--|

# PG Simulation

## 3D Processing Simulation System

- Processing simulation with the same tool layout/condition as in a real-life
- Prevent collisions with simulation in advance
- Easy for new operators with the OP panel to practice

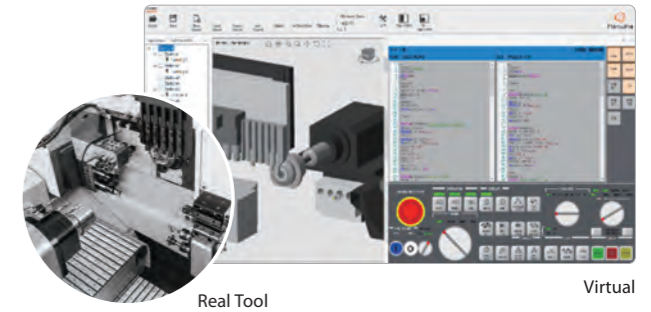

# PG Editor

## Easy, Quick, Convenient Programming Guide Solution

- PC based (Fanuc), NC based (Siemens)

- Easy program creation
- Provides a preview on expected result in 3D
- Minimize time loss by with the pre-check typo



# PG Manager

## Simple, Efficient, Safe Data Managing Solution

- Drawing, Program, Tool & Option List

- Save & build-up your production data
- Search & find similar production data as needed
- Support reference by each machining condition



# Automobile

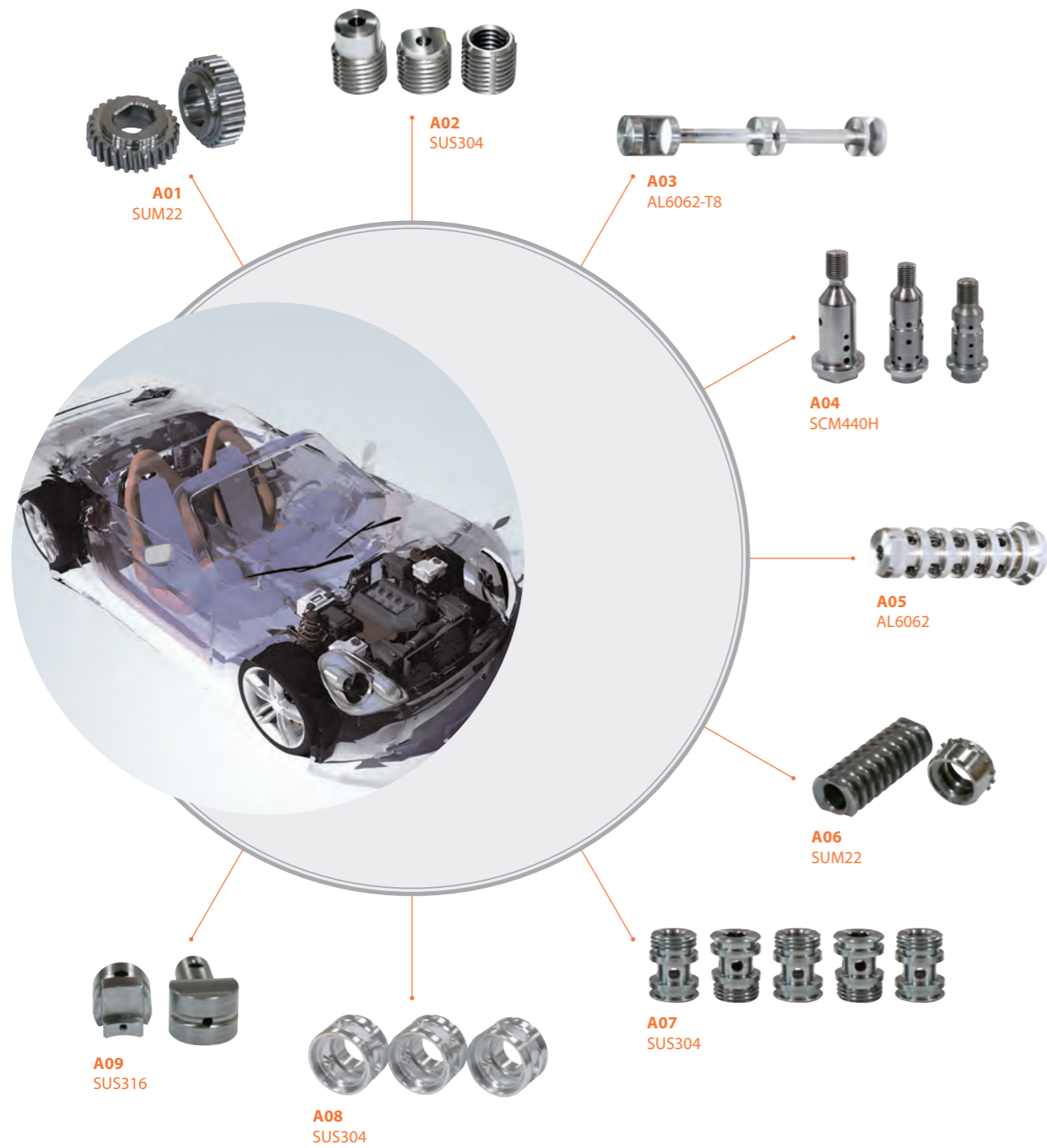

# Electronic



# Medical

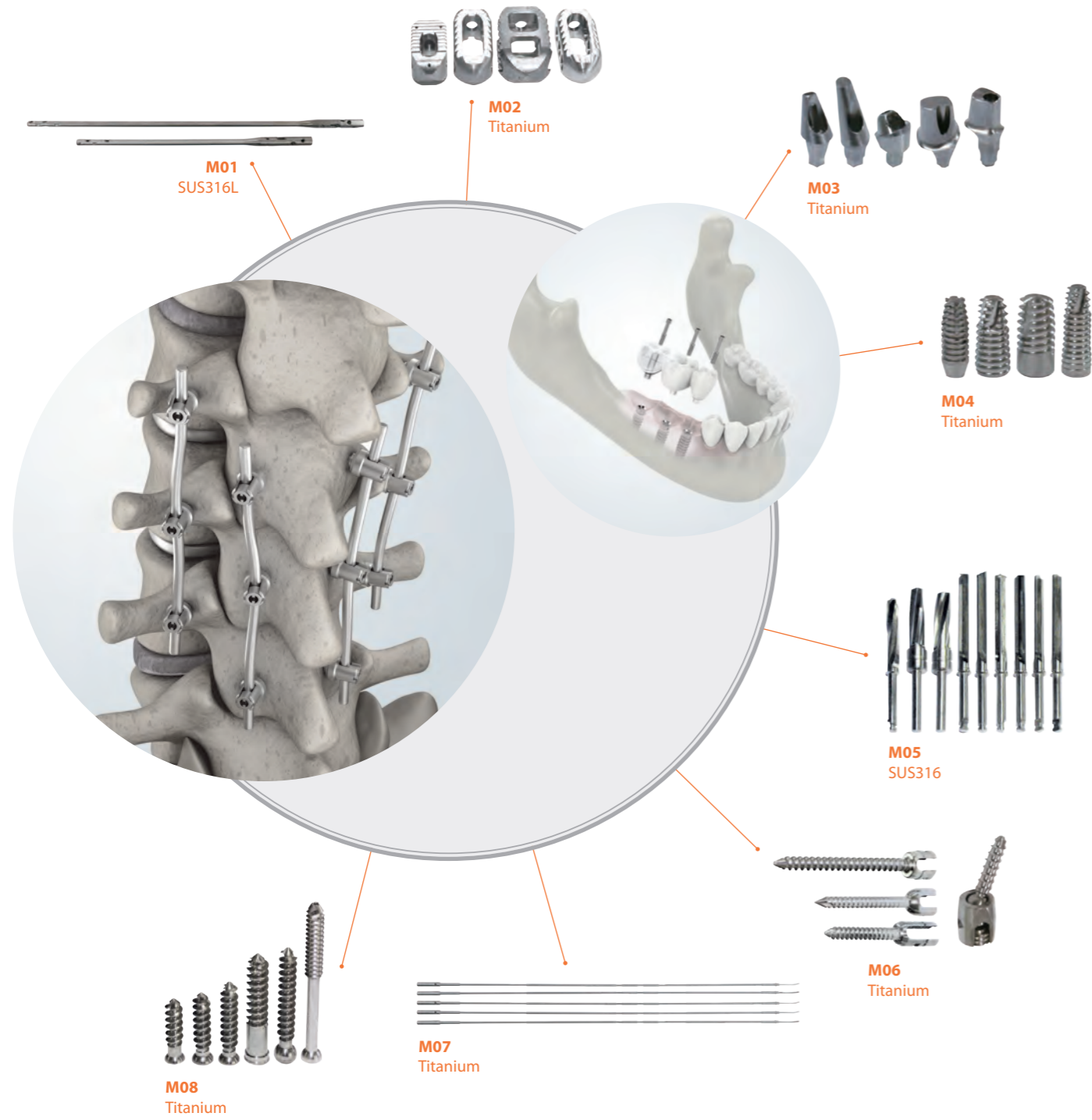

# Industrial

